

**MAKE X**

**V2.0**

# 机器人挑战赛

Robotics Competition

**2024 - 2025**

## **RULES GUIDE**

### **MAKEX CHALLENGE**



**2025.01**

[www.makex.cc/en](http://www.makex.cc/en)





Date	Version	Modifications Record
2024.01	1.0	MakeX Challenge Ultimate Winner Rules Guide First Publish.
2024.07	1.1	<p>4.2 Arena</p> <ul style="list-style-type: none"> <li>Optimized the illustration of the starting area</li> </ul> <p>4.3 Props</p> <ul style="list-style-type: none"> <li>Optimized the requirement of resource placement</li> </ul> <p>5.1 Specification of Robot Construction</p> <ul style="list-style-type: none"> <li>Optimized the description of the robot construction</li> </ul> <p>6.0 Competition Rules</p> <ul style="list-style-type: none"> <li>6.2 Security Rules</li> <li>6.3 Contestants' Requirements</li> <li>6.4 Operation Rules</li> <li>6.5 Modification Rules</li> <li>Updating the penalties for the competition, adding descriptions of penalties for specific behaviors, please refer to the rules above for details.</li> </ul>
2025.01	2.0	<p>2. Competition Application</p> <ul style="list-style-type: none"> <li>Updated the birth range of participants</li> </ul> <p>3. Competition Procedure</p> <ul style="list-style-type: none"> <li>Optimized the description of Robot inspection</li> <li>Optimized the description of the Engineering notebook submission</li> </ul> <p>4. Competition Details</p> <ul style="list-style-type: none"> <li>Optimized the description of 4.1 Introduction</li> <li>Updated "Fig 4.1"</li> <li>Updated the description of "own resource area"</li> <li>Updated the description of the "central resource area"</li> </ul>



	<ul style="list-style-type: none"> <li>● Updated the description of the “two-layer recycling area”</li> <li>● Updated “4.4 Mission”</li> <li>● Optimized the description of the result confirmation in “4.6 Match flow”</li> </ul> <p>5. Technical Specifications</p> <ul style="list-style-type: none"> <li>● Optimized the description of “Specification for Team Flag”</li> </ul> <p>6. Competition Rules</p> <ul style="list-style-type: none"> <li>● Optimized the description of “6.1 Penalty”</li> <li>● Optimized the description of “Malicious complaint” in “6.3 Participant Behavior Rules”</li> <li>● Added the description of “Code of Conduct for the Final Stage”</li> </ul> <p>7. Appeal and Arbitration</p> <ul style="list-style-type: none"> <li>● Optimized the description of “7.1 Results Confirmation” &amp; “7.2 Appeal Procedure and Valid Appeal Period”</li> <li>● Updated the “Appendix 4 MakeX Challenge Score Sheet”</li> </ul> <p>Updated Appendix 4 MakeX Challenge Score Sheet Updated Appendix 8 Arena Assembly Instruction</p>
--	---



# CONTENTS

- 1. Introduction..... 1**
  - 1.1 *About MakeX.....1*
  - 1.2 *MakeX Spirit.....1*
  - 1.3 *About MakeX Challenge.....2*
- 2. Competition Application..... 3**
  - 2.1 *Participation Requirements .....3*
  - 2.2 *Registration and Application .....3*
- 3. Competition Procedure..... 4**
- 4. Competition Details ..... 9**
  - 4.1 *Introduction.....9*
  - 4.2 *Arena .....10*
  - 4.3 *Props .....19*
  - 4.4 *Missions .....22*
  - 4.5 *Scoring Explanation .....28*
  - 4.6 *Single Match Flow .....29*
- 5. Technical Specifications ..... 32**
  - 5.1 *Specification for Robot Construction .....32*
  - 5.2 *Specification for Team Flag.....38*
- 6. Competition Rules ..... 39**
  - 6.1 *Penalty.....39*
  - 6.2 *Safety Rules .....41*



6.3 Participant Behavior Rules.....43

6.4 Operation Rules.....45

6.5 Modification Rules.....48

**Modify Outside the Designated Area..... 49**

**7. Appeal and Arbitration ..... 50**

7.1 Results Confirmation .....50

7.2 Appeal Procedure and Valid Appeal Period.....50

7.3 Invalid Appeal.....51

7.4 Arbitration Procedure .....52

**8. Statement ..... 52**

8.1 Rules Explanation.....53

8.2 Disclaimer.....53

8.3 Copyright Declaration.....54

**Appendix 1. Awards and Annual Points..... 55**

**Appendix 2. Engineering Notebook Guideline..... 57**

**Appendix 3 Robot Self-Check Form..... 59**

**Appendix 4 MakeX Challenge Score Sheet..... 63**

**Appendix 5 Instructions for Li-Po Battery ..... 64**

**Appendix 6 Power Management Module ..... 66**

**Appendix 7 Supplementary Explanation of Competition Procedure .. 71**

**Appendix 8 Arena Assembly Instruction..... 73**

**Appendix 9 Competition Resources ..... 75**



# 1. Introduction

## 1.1 About MakeX

MakeX is an international robotics competition and education platform that promotes multidisciplinary learning within the fields of science and technology. It aims at building a world where STEAM education is highly appreciated and where young people are passionate about innovation by engaging them in exciting Robotics Competition, STEAM Carnival, Tech Event, Educational Conference etc.

As the core activity of MakeX, the namesake MakeX Robotics Competition provides exciting, challenging and high-level competitions in the spirit of creativity, teamwork, fun and sharing. It is committed to inspiring young people to learn Science (S), Technology (T), Engineering (E), Art (A) and Mathematics (M) and apply such knowledge in solving real-world problems.

## 1.2 MakeX Spirit

**Creativity:** we advocate curiousness and innovation, encouraging all contestants to create unique high-tech works with their talent, and challenge themselves for continuous progress!

**Teamwork:** we advocate solidarity and friendship, encouraging all contestants to develop a sense of responsibility and enterprising spirit, and sincerely work with their partners for win-win development!

**Fun:** we encourage contestants to build a positive, healthy mindset in the competition. Enjoy the journey and grow in the process.

**Sharing:** we encourage contestants to have an open mind as a maker and share their knowledge, responsibility, and joy with everyone, including their teammates and competitors.

MakeX spirit is the cultural cornerstone of the MakeX Robotics Competition. We hope to provide a platform for all contestants, mentors and industry experts to exchange



ideas, study and grow up, and help young people acquire new skills during creation, learn to respect others in teamwork, gain an enjoyable life experience in the competition, take delight in sharing with the society their knowledge and responsibility, and work hard to achieve their grand aspiration of changing the world and creating the future !

### **1.3 About MakeX Challenge**

MakeX Challenge is a highly confrontational competition program for students between the age of 11-18.

This program is very confrontational and enjoyable to watch, and the simple and easy-to-understand rules enhance the overall experience of participation and engagement. The design and construction of bigger robots and programming can better improve the contestants' design abilities and multi-dimensional thinking abilities of advanced robots. Also, the contestants are exercising logical thinking, strategic analysis, communication and cooperation, and improving decision-making abilities in the competition.



## 2. Competition Application

### 2.1 Participation Requirements

**Participants:** Contestants shall participate in a team. The number of contestants is 2-8 for each team, with 1-2 mentor(s).

**Age:** Team members must be teenagers or children between 11 and 18 (born between January 2, 2006 and December 31, 2014). The mentor must be at least 18 years old.

**Team Roles:** Everyone in the team can play their respective roles as operator, observer, mechanist, programmer and so on. In each match, one team can only appoint 1 operator and 1 observer to participate, only two team members are allowed to compete in the competing area. The operator is responsible for operating the robot, and the observer is responsible for assisting the operator in observing the status of props and making suggestions.

**Identification Symbols:** Each team must have a logo, name, and slogan. Teams are encouraged to use uniforms, flags, posters, badges, base decorations, etc. to show the team culture.

### 2.2 Registration and Application

Contestants and mentors who meet participation requirements can register on the designated competition webpage on the MakeX official website ([www.makex.cc/en](http://www.makex.cc/en)). Each team should register with one registration form.

If a participating team wants to change their members before the competition, which leads to inconsistency with the registration information, they should inform the MakeX Robotics Competition Committee in advance to finish re-registration.

For more details about the registration and application, please refer to [MakeX Registration & Competition Application Guide](#)



### 3. Competition Procedure

Participating teams shall pay close attention to related notices and competition guides published before each competition. If there are some updates in the competition guide, the latest rules will be adopted for the competition. MakeX Robotics Competition Committee reserves the rights and final interpretation to amend competition rules and system based on the actual situation of different points races. The schedule for each competition is determined by the actual situation and generally includes the following procedures.

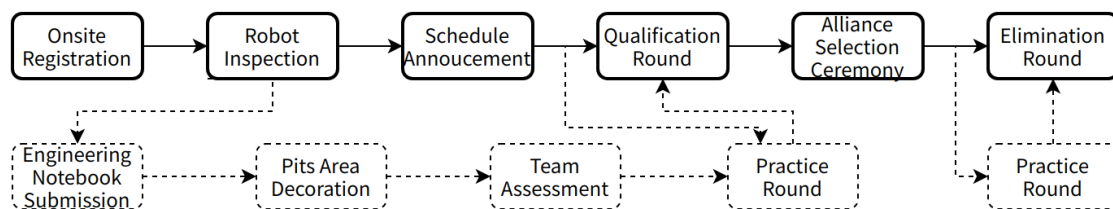

\* Note: The solid line frame refers to the necessary procedure of each match, while the dotted line frame refers to the non-essential procedure. Please keep abreast of updates.

#### Onsite Registration

When a team arrives at the venue, mentors and contestants should show ID cards or other valid certificates (e.g. passport) for onsite registration and to get the competition pack. Mentors must inform team members about the fire exit, match schedule, competition area, practice area pits area, etc. Onsite registration and robot inspection will be conducted once the match schedule is generated.

#### Robot Inspection

Teams shall check their robots and self-made props before the competition and complete the "**Appendix 3: Robot Self-Inspection Form**" according to the actual data. Teams that do not fill out the Robot Self-inspection Form in full according to the requirements cannot pass the inspection.

Before the competition, participating teams are obligated to conduct a self-check and



mutual check on their robots and the opposing robots once again. They must promptly rectify any issues before entering the competing area.

Once get in the competing area, malicious complaints are not allowed (refer to 6.2, Operation Rule-R31 for the definition of malicious complaints). Participating teams must raise their hands in response to the referee's instructions to confirm that both robots are in proper condition before starting the match. Without a complaint, on-site inspections of robots are not permitted after this confirmation.

### Schedule Announcement

The committee will announce the match schedule at least 30 minutes before the competition starts through online official website and onsite announcement. The schedule includes a match-up chart, match session and specific time, red alliance and blue alliance, etc. If the two rounds of match are too closed, please register at the Result Approval Desk.

### Engineering Notebook Submission

Each team is required to submit 1 paper copy of their team's engineering notebook to the MakeX staff at the inspection area. If you are unable to submit the original version, please prepare your paper copy. The engineering notebook will be used as an important basis for the selection of the special awards, and the paper version of the engineering notes will not be returned after submission. Please refer to the pre-match announcements and competition guide for the submission of paper engineering notebooks and awards for each competition. For suggestions on how to write the engineering notebook, please refer to "**Appendix 2: Engineering Notebook Guideline**".

### Practice Round

Teams who have finished their robot inspection can participate in the practice round. The schedule will be announced at the entrance in the form of notices, and teams are required to queue in line before the entrance. Not all competitions have a practice round, which can be informed based on the actual situation.

### Waiting for the competition



In regular competitions, a waiting area will be designated, and volunteers will announce or post information about the matches awaiting in that area. Participating teams are advised to pay attention to the waiting notifications and proceed to the corresponding waiting area according to the provided schedule.

### Qualification Round

Normally, each team is requested to participate in four matches during the qualification round. However, the session of the qualification round may be different based on different competitions. In the qualification round, the red alliance and the blue alliance are matched randomly. Points will be obtained by teams according to the winning or losing situation. It is conducted in the form of alliance confrontation and each team's alliance and the opponents will be allocated randomly.

In each qualification round, the team will receive corresponding points (including win, tie, and loss) regardless of competition type. Three points for a win, one point for a tie, and no point for a loss. The final ranking is based on the sum of win-loss points, and the top-ranking teams will be promoted to the elimination round.

If the team with the same win-loss points, the ranking sequence will be determined according to the following rules:

- 1) The team with a higher total points differential of all qualification rounds has a higher ranking.
- 2) If the above conditions are the same, the team with higher total scores among all qualification rounds has a higher ranking.
- 3) If the above conditions are the same, the team with the highest score of a single round in all qualification rounds has a higher ranking.
- 4) If the above conditions are the same, teams with the same ranking will play a one-on-one extra match, and those with the highest total points will be the winner.

### Alliance Selection Ceremony

In the alliance selection ceremony, promoted teams will select their alliance team in



turn according to their ranking in the qualification round. Alliances that are generated after the ceremony will be the alliances for the elimination round. The alliances will be named “Alliance 1”, “Alliance 2”, “Alliance 3” ..... and so on according to the generated sequence. During this procedure, teams must abide by the following rules:

When being chosen by other teams, promoted teams ranking top 50% can refuse only once, and those teams ranking bottom 50% cannot refuse. If the team is refused by another team, they can continue to choose another team until the alliance is formed.

The promoted teams who are not present before the start of alliance selection are deemed as voluntarily giving up the right to choose an alliance and those who are not present before the end of the alliance selection are considered to be as voluntarily quitting the elimination round. If the promoted teams quit amid the alliance selection ceremony, the promotion places will be given to the following teams according to the ranking in the qualification round.

During the alliance selection ceremony, each team representative will have 30 seconds to make their decision when it is their turn, and if they are not selected within the 30-second time limit, they will lose the right to select and will move on to the next team in order.

The promotion proportion for the 2024-2025 season competition is as follows. However, the promotion quota in different competitions may be different according to the actual situation.

Number of participating teams	Number of promoted teams
97 or more	64
49-96	32
25-48	16
12-24	8

### Elimination Round

During the elimination round, the alliances generated in the alliance selection



ceremony will be the opponent (red alliance and blue alliance are automatically matched) according to the competition schedule. The winner will be evaluated by BO3(Best of 3) and the alliance that achieves "two wins" or "one win and two ties" can advance to the next round until the champion, runner-up and second runner-up are elected.

If the two alliances achieve "1 win, 1 loss, 1 tie" or "3 ties" in a BO3, the winning alliance will be decided according to the following rules:

- 1) If win-loss points are the same, the alliance with a higher total point differential in BO3 has a higher ranking.
- 2) If the above conditions are the same, the alliance with the highest scores in BO3 has a higher ranking.
- 3) If the above conditions are the same, alliances will play an extra match until the winner is elected.

Taking the promoted 32 teams as an example, the schedule of the elimination round is as follows:







## 4. Competition Details

The theme of the 2024-2025 Season MakeX Challenge is "Ultimate Winner".

### 4.1 Introduction

Each single match lasts for 4 minutes and 40 seconds.

MakeX Challenge Ultimate Winner is a confrontational competition, among which red and blue alliances for each match, and two teams for each alliance.

Each match comprises four stages: automatic stage, manual stage, modification stage and final stage. The participating teams need to complete the corresponding missions according to the requirements of the competition by automatically controlling the robot through the program or manually manipulating the robot. At the end of the match, the referee calculates the sum of both teams' scores for each mission, and the alliance with the highest score will win the match.



Fig 4.1 Axonometric View of Competition Arena

## 4.2 Arena

The competition arena of MakeX Challenge Ultimate Winner consists of a map and frame. It is a rectangular area with a size of 4640mm\*3040mm and the frame's height is 400 mm. The arena mainly consists of the starting area, the own resource area, the flag hanging area and the central resource area which consists of a two-layer recycling area, the reversed flag area and the central resource island, etc. Due to measurement and wear of field props, the actual product may have a  $\pm 5\text{mm}$  deviation from the description.

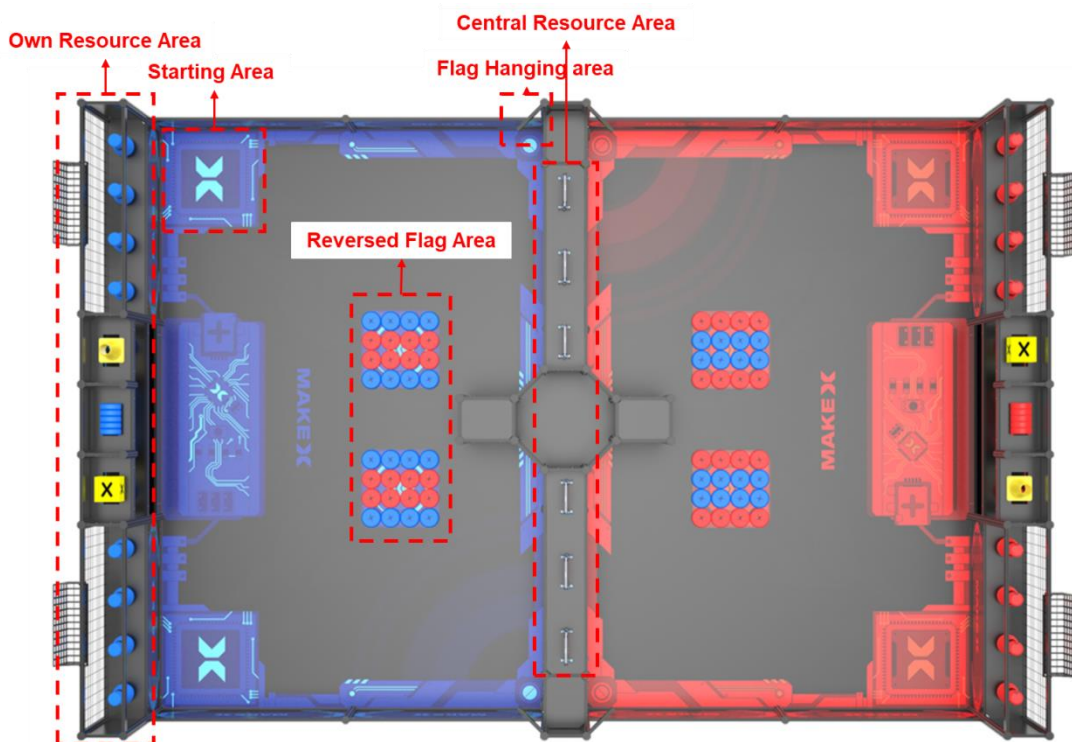

Fig 4.2-1 Top View of Competition Arena

The arena is evenly divided into the red and blue camps, with the central resource area located in the central area. Robots are only allowed to conduct corresponding missions in their respective camp except for the final stage. During the final stage, the robots are allowed to go into the opponent's area as permitted by the rules.

### Starting Area

The starting area is where robots are placed before the competition, they are located at the four corners of the arena. There are two starting areas for each red alliance and



blue alliance., with the size of 500mm × 500mm

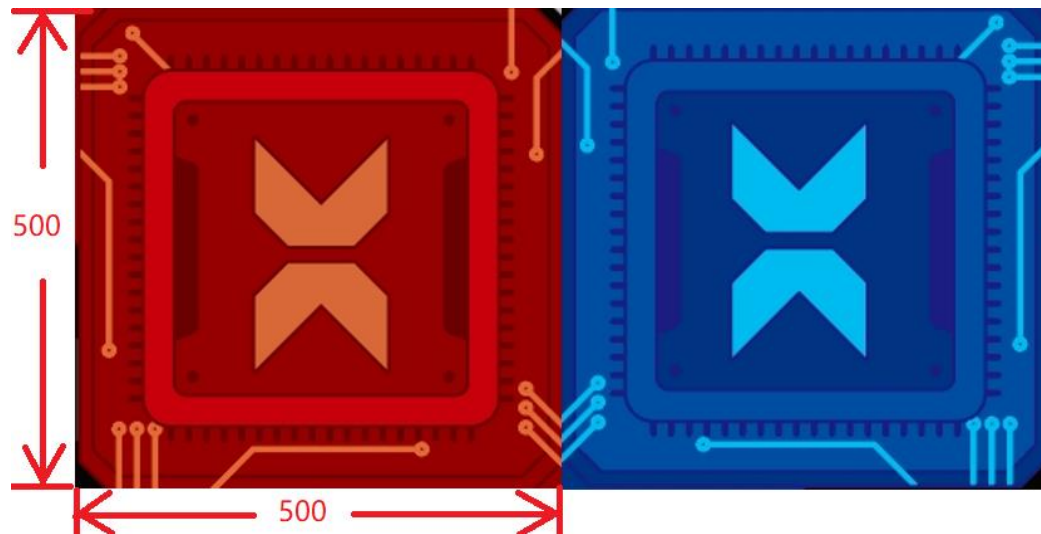

Fig 4.2-2 Starting Area

**Own Resource Area**

There is one the own resource area for each camp, which consists of 3 areas with dimensions of 200mm(width)\*986mm(length), each area placed with 4 pins. In each area, the distance between each pin is the same. There are 12 pins in each camp. There is an “own smelter area” located below the own resource area.

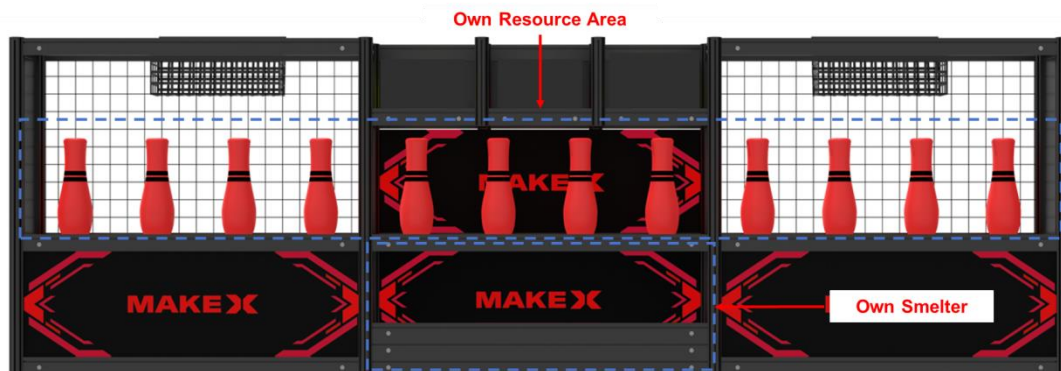

Fig 4.2-3 Own Resource Area (Front View)

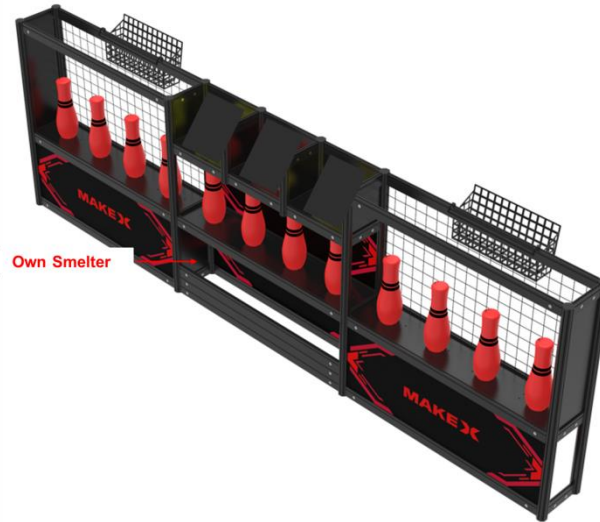

Fig 4.2-4 Own Resource Area (Axial View)

Central Resource Area

There is one central resource area located between the two camps with a dimension of 3040mm\*1044mm. The Central Resource Area consists of the Reversed Flag Area, the Movable Resource Island, the Central Resource Island and the Two-layer Pin Recycling Area. The size of the reversed flag area is 1000mm\*200mm and the size of the removable resource island is 1000mm\*200mm.

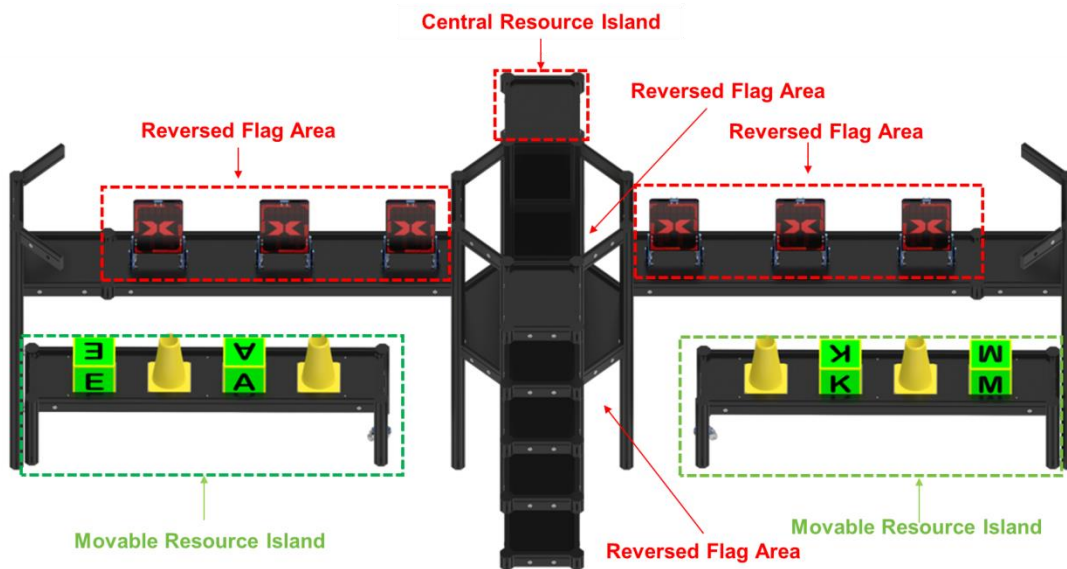

Fig 4.2-5 Central Resource Area (Axial View)

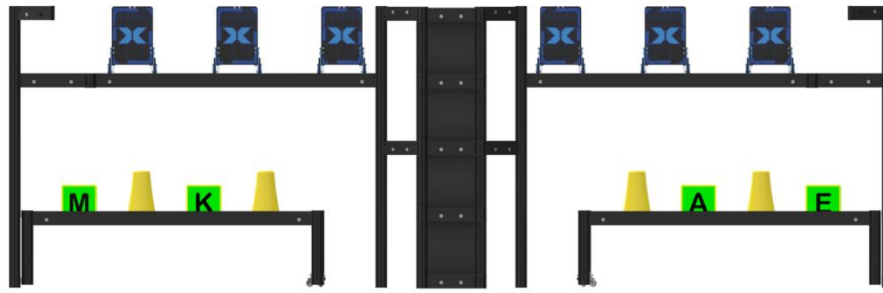

Fig 4.2-6 Central Resource Area (Front View)

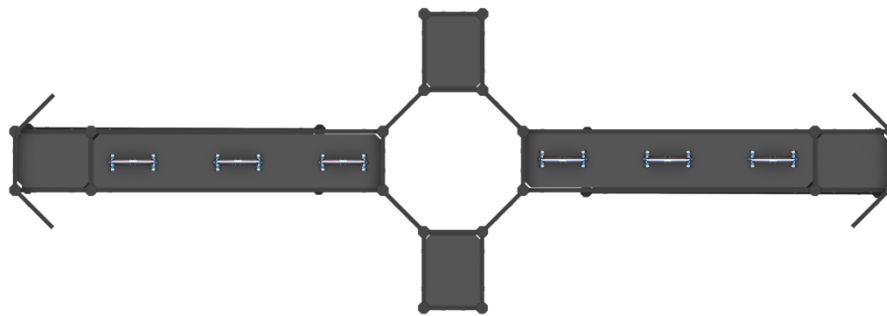

Fig 4.2-7 Central Resource Area (Top View)

### Reversed Flag Area

The reversed flag area is located in the upper layer of the left and right part of the central resource area. Each side of the reversed flag area has been fixed with 3 reversal flags, of a total of 6 reversal flags at the reverse flag area. The size of the reversal flag is 142 mm\*200 mm. The distance between the bottom of the reversal flag and the ground is 763mm, and two adjacent reversal flags on the same side are 218mm apart.

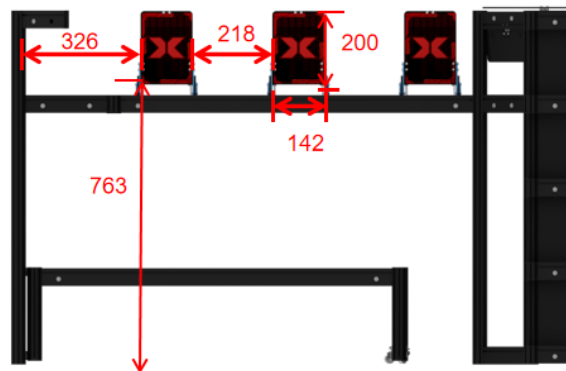

Fig 4.2-8 Reversed Flag Area(Front View)





**Movable Resource Island**

The movable resource island is located in the lower layer of the left and right part of the central resource area. At each side of the movable resource island, there are 2 alphabet cubes and 2 cones respectively placed in the groove with the dimension of each groove being 120mm\*120mm\*20mm (length\*width\*height). The position of the cubes and cones are fixed as shown and cubes are placed in a randomized order. The height from the ground to the top of the resource island is 252mm. The portion size of the alphabet cube protruding from the resource island is 90mm, and the portion size of the cone protruding from the resource island is 140mm. The bottom of the movable resource island is equipped with movable rubber wheels, which can be rotated unidirectional around the axle. The movable resource island facing the left side of the central resource area is the movable resource island that can be pushed out by its alliance, with the left and right sides being symmetrically arranged in the centre.

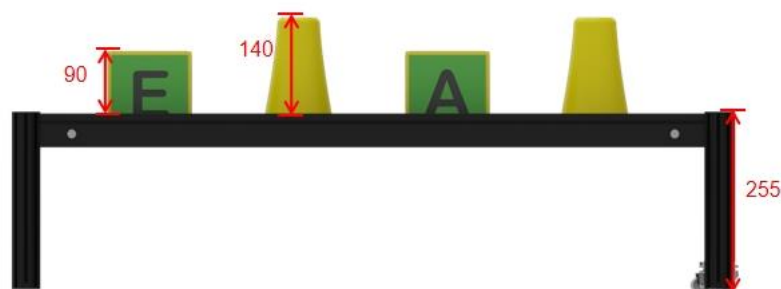

**Fig 4.2-9 Movable Resource Area(Front View)**



**Fig 4.2-10 Movable Resource Area(Top View)**



Fig 4.2-11 Groove (Top View)



Fig 4.2-12 Groove (Front View)

### Two-layer Pin Recycling Area

The two-layer pin recycling area is located in the centre of the two camps and it is an octagonal shape that consists of a flat beam with a length of 160mm and an octagonal pillar, with an internal diameter of 465mm and an overall height of 960mm. There are four recycling ports with dimensions of 405mm\*160mm on the sides of the recycling area, located on the four inclined sides.

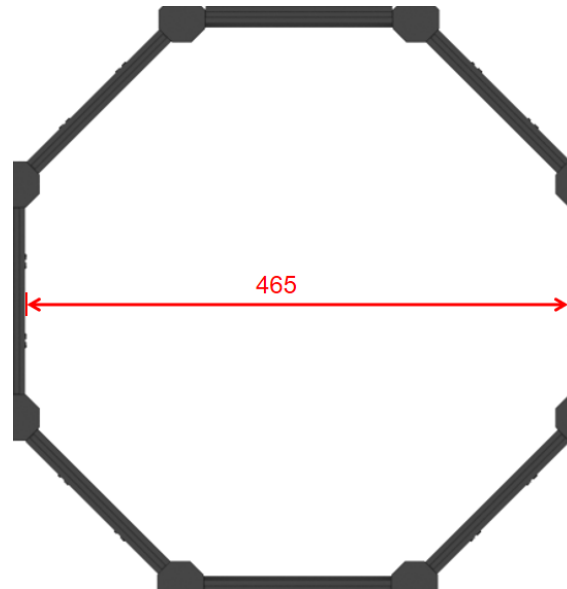

**Fig 4.2-13 The two-layer pin recycling area (Top View)**

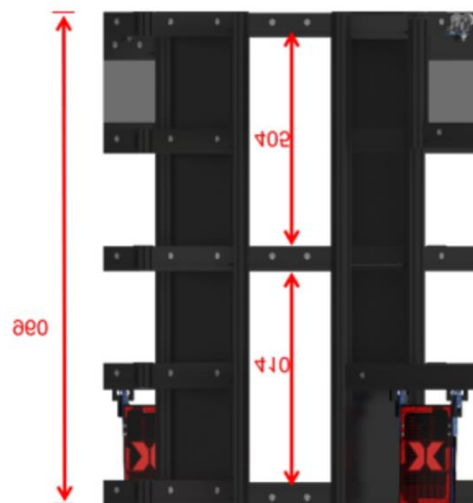

**Fig 4.2-14 The two-layer pin recycling area (Front View)**

### Central Resource Island

The central resource island is located in the central position of the two camps, the red and blue camps each have one central resource island. The central resource island is composed of five rectangular resource trays made with 160mm and 220 flat beams and octagonal pillar, combined in regular rows perpendicular to the ground, with an overall height of 965mm, the lowest resource tray is 49mm from the ground, and the vertical distance between the two adjacent resource tray is 228 mm.

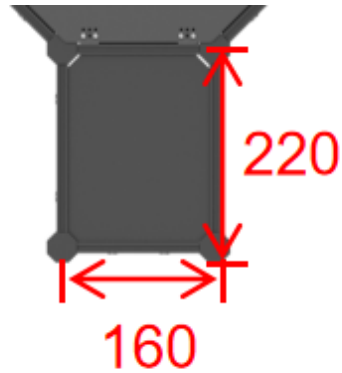

Fig 4.2-15 Resource Tray (Top View)

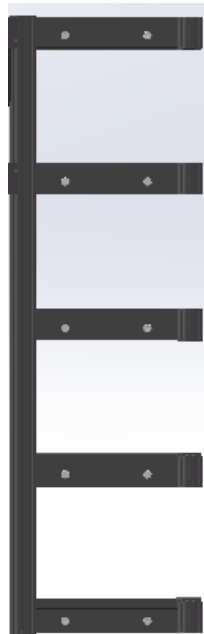

Fig 4.2-16 Central Resource Island (Side View)

### Flag Hanging Area

Each side of the camps has 2 symmetrical flag hanging devices, a total of 4 in the whole arena, the height of the flagpole from the ground is 960mm, the length of its transverse flat beam is 160mm, the flat beam is oriented towards the field and the side frame is at 45 degrees.

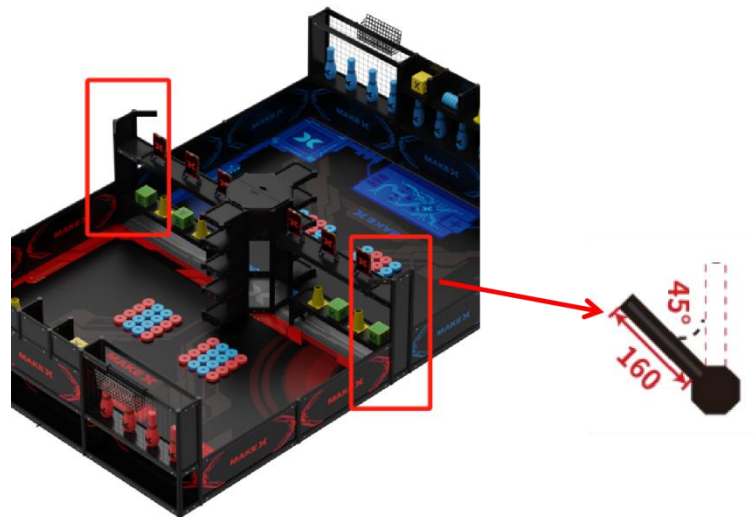

Fig 4.2-17 Flag Hanging Area (Side View)

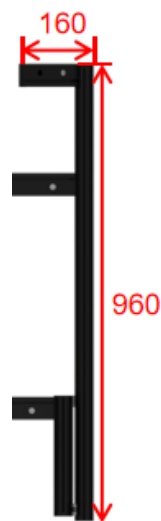

Fig 4.2-18 Flag Hanging Area (Front View)

### Discs Placement Area

Each side of the camps has two “disc placement areas” with a dimension of 400 mm\*400 mm. Each area has placed 16 pieces of discs with the diameter of the disc 100 mm. The disc placement in the red camps is shown in Fig 4.2-19 and the disc placement in the blue camps is shown in Fig 4.2-20.



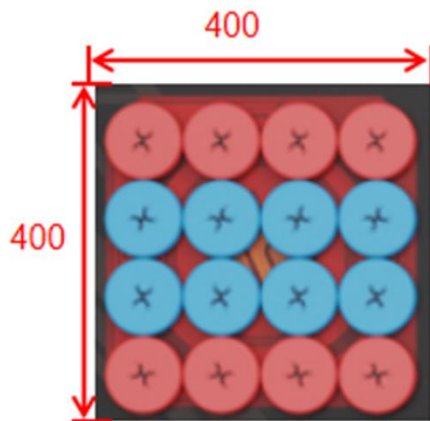

Fig 4.2-19 Red Alliance Discs Placement Area (Top View)

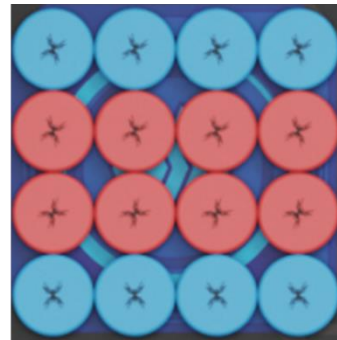

Fig 4.2-20 Blue Alliance Discs Placement Area (Top View)

### 4.3 Props

The initial position of the props before the match is shown in figure:

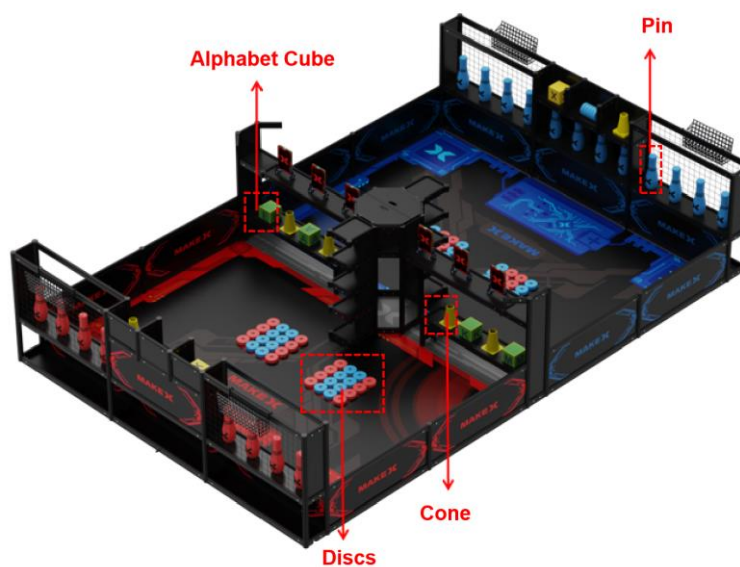

Fig 4.3-1 Arena Prop Placement

#### Discs

The red/blue discs are placed in the disc placing area in both camps. The material of the discs is EVA and the dimension is 30mm(height) and diameter 100mm. Before the start of the match, each disc placement area will be placed with 16 pieces of discs and another 5 red/blue discs for the team’s benefit will be placed outside the arena. A total of 74 discs for each arena.

**Fig 4.3-2 Blue Discs****Fig 4.3-3 Red Discs**

### Pins

The red/blue pins are placed in their own resource area at each camp. The material of the discs is EVA. The height of each pin of 290mm, the diameter of the bottom of each pin is 70mm, and the maximum diameter is 100mm. Each camp has 12 pins and a total of 24 pins in the arena.

**Fig 4.3-4 Blue Pin****Fig 4.3-5 Red Pin**

### Alphabet Cube

Alphabet cubes are placed in the movable resource island at the central resource area in the arena. It is made of EVA with an edge length of 120 mm with the bottom side having a hollow cross hole (as shown). There are 4 cubes in total. The alphabet cube labelled with "M," "A," "K," and "E" each have one, and the cube labelled with "X" is not set in the arena. It can only be obtained by completing missions. This prop is a common prop for both participating alliances. (Note: A tolerance of  $\pm 5$ mm is permitted for all props)

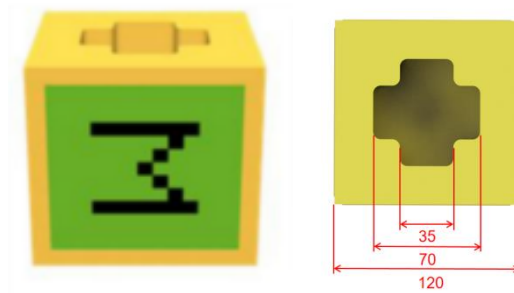

**Fig 4.3-6 Alphabet Cube**

### Cone

The cone is placed on the movable resource island in the resource area in the central resource area of the arena. Material: EVA. Dimension: the overall height is 170mm, the pedestal is a square with a side length of 120mm\*120mm, a height of 20mm and a rounded corner with a rounded hollow in the centre of 80mm in diameter; the upper part is a rounded corner with a diameter of 100mm at the lower bottom and 60mm at the upper bottom with a rounded hollow in the centre of 50mm in diameter. There are 5 cones in total, one of the cones is not set in the arena. It can only be obtained by completing missions. This prop is a common prop for both alliances.



**Fig 4.3-7 Cone (Front View)**

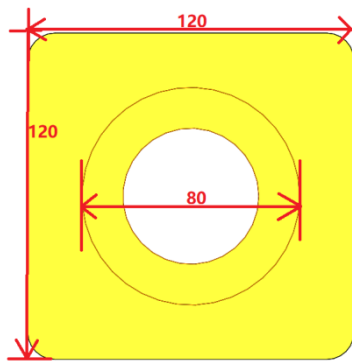

**Fig 4.3-8 Cone(Elevation view)**

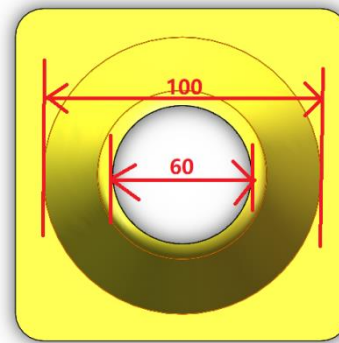

**Fig 4.3-9 Cone(Top View)**

\* Note: All arenas and props have certain and reasonable tolerances. If there are any objections to the size of the props or other problems, the captain of the alliance can apply for replacement before the match, and the final decision is on the referee.

### 4.4 Missions

The competition unfolds through various stages, including the automatic stage, manual stage, modification stage and final stage. Mission details of each stage are detailed below:

Stage	Mission Details	Operation Area
Automatic Stage (30 seconds)	(1) Scrambling for resources (2) Transporting pins (3) Precision pitching (4) Hitting the reversal flag	Individual Camp
Manual Stage (100 seconds)	(1) Scrambling for resources (2) Transporting pins (3) Precision pitching (4) Hitting the reversal flag	Individual Camp
Modification Stage (60 seconds)	Modification of individual robots	Off-site



Final Stage  (90 seconds)	(1) Scrambling for resources  (2) Knocking out the pins  (3) Shooting the discs into the smelter  (4) Hitting the reversal flag  (5) Hanging the team flag	Whole arena
---------------------------------	--	-------------

**Scrambling for Resources**

**Operation Stage:** Automatic Stage, Manual Stage, Final Stage.

**Missions Details:** Robots are tasked with securing alphabet cubes or cones from the movable resource island located in the central resource area. The objective is to accurately position these alphabet cubes or cones into the five resource trays on their respective central resource island.

**Scoring State Judgement:** It's regarded as a valid state if the vertical projection of the alphabet cube or cone is entirely within the resource trays of their corresponding central resource island, and there is no interaction between the props and the robot.

**Mission Points:** Each correctly placed alphabet cube or cone is awarded 30 points. An additional bonus of 200 points is granted if all five resource trays on a central resource island are filled with valid alphabet cubes or filled with valid cones.

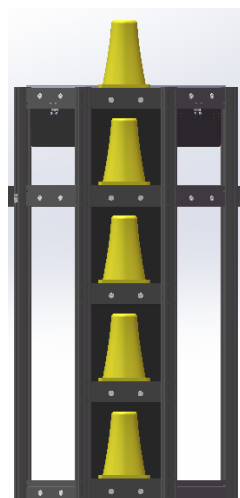

Fig 4.4-1 Cone Placement(Front view)

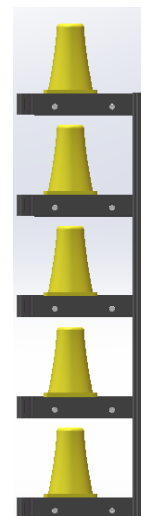

Fig 4.4-2 Cone Placement(Side view)





## Transporting pins

**Operation Stage:** Automatic Stage, Manual Stage, Final Stage.

**Missions Details:** Robots are tasked with transporting the respective color's pins to the two-layer pin recycling area.

Scoring State Judgement:

a. The vertical projection of the pin is at least partially entering the upper pin recycling area and the robot has no direct contact with any pins in the upper pin recycling area. Otherwise, all pins of the respective color that have entered the upper pin recycling area are invalidated.

b. The vertical projection of the pin completely enters the lower pin recycling area, with the outer edge of the flat aluminum of the recycling area as the boundary of determination, and there is no direct contact between the robot and any of the pins in the lower pin recycling area, or else all pins of the respective color that have entered the lower pin recycling area are invalidated.

**Mission Points:** At the scoring time, each pin of the respective color that is successfully carried to the upper pin recycling area receives 20 points, and each pin of the respective color that is successfully carried to the lower pin recycling area receives 30 points.

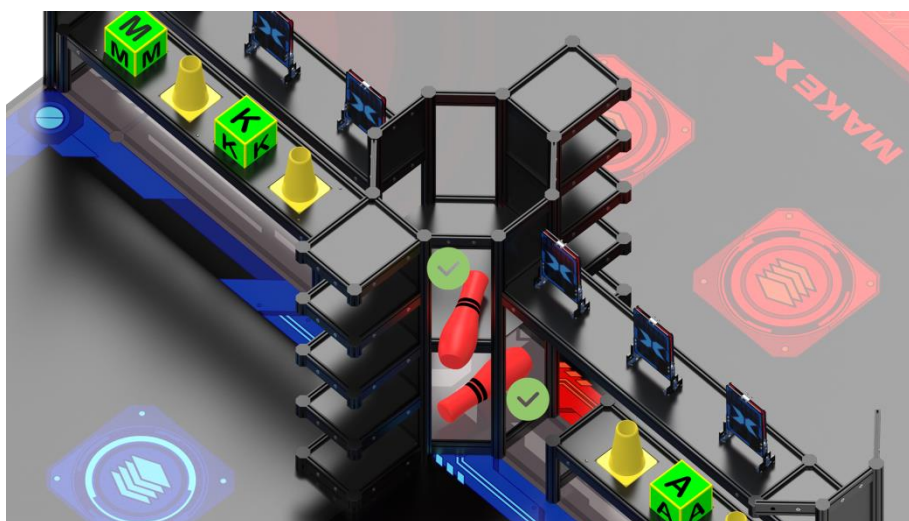

Fig 4.4-2 Cone Placement (Side view)





from the alliance may enter the opponent's camp. Concurrently, the alliance may select one benefit from the options below. If an alliance successfully tilts all reverse flags on both sides of the reverse flag area toward the opponent, they may choose two benefits, the two benefits can't be identical. The benefit options are:

- a. Gain 1 alphabet cube marked "X".
- b. Gain 1 cone
- c. Gain 5 discs

Upon receiving the benefits, alliances must place the acquired resources (props) partially or completely into any starting area of one's own camp before the final stage.

### Hanging the Team Flag

Operation Stage: Final Stage.

**Missions Details:** Robots are authorized to suspend the team flag on the flagpole located either in their own or the opponent's flag-hanging area. Each team may introduce one flag into the arena per match.

**Scoring State Judgement:** A flag hanging is deemed valid if, during the scoring moment, the flag is affixed to the flagpole without any contact with the ground or the robot. The flag must be in a naturally unfurled state and adhere to the prescribed manufacturing standards (in which the flag must contain the "team name", which must be the team name of the participating team and may not be labelled with or used the name of another team's flag). A flag that remains folded due to contact with other elements is classified as an invalid hanging.

**Mission Points:** A valid flag hanging in the own camp earns 50 points. Conversely, a valid flag hanging in the opponent's camp secures 80 points. There is no limit to the number of valid flags in either camp's hanging area.

### MakeX Bonus

**Operation Stage:** Automatic Stage, Manual Stage, Final Stage.

**Missions Details:** Robots are tasked with collecting five alphabet cubes and arranging



them in a vertical sequence from top to bottom as [M] [A] [K] [E] [X] in the resource trays of their respective central resource island.

**Scoring Statement Judgement:** A scoring state is acknowledged if five alphabet cubes are orderly positioned from top to bottom as [M] [A] [K] [E] [X] in the resource trays of the respective central resource island. The vertical projection of each alphabet cube must entirely occupy the corresponding resource area without any contact with the robot.

**Mission Points:** A successful MakeX Bonus sequence is awarded an additional 100 points.



Fig 4.4-3 Cube Placement (Front view)

Fig 4.4-4 Cube Placement (Side view)

### Boundary State Judgement

During the match, if there is any uncertainty about the position of the robot (or props) and designated boundary, the following state judgement can be explained:



## 4.5 Scoring Explanation

The final score of the match is determined by the final static state of the scoring prop after the match. Competition missions, scoring props and their corresponding points are as follows. After the competition, the referee calculates the sum of the scores of each mission, and the alliance with the higher score will be the winner.

Scoring Props	Details of Scoring Props	Single Prop's point	Maximum Quantity	Maximum Point
Disc	Discs of respective color in the opponent's smelter	10	37	370
Pin	Valid Pin in the upper recycling area	20	12	240
	Valid Pin in the lower recycling area	30	12	360
Reverse Flag	Reverse flag tipped to opponent's camp	30	6	180
Alphabet Cube	Alphabet cube placed in the central resource island in a valid state	30	5	150
	Five alphabet cubes all placed in the central resource island in a valid state	200	1	200
	Alphabet cubes placed in the central	100	1	100



	resource island in the order of “MAKEX” from top to bottom			
Cone	Cone placed at the central resource island in a valid state	30	5	150
	Five cones all placed in the central resource island in a valid state	200	1	200
Team Flag	Valid Flag in Own Flag Hanging Area	50	2	100
	Valid Flag in Opponent’s Flag Hanging Area	80	2	160

### 4.6 Single Match Flow

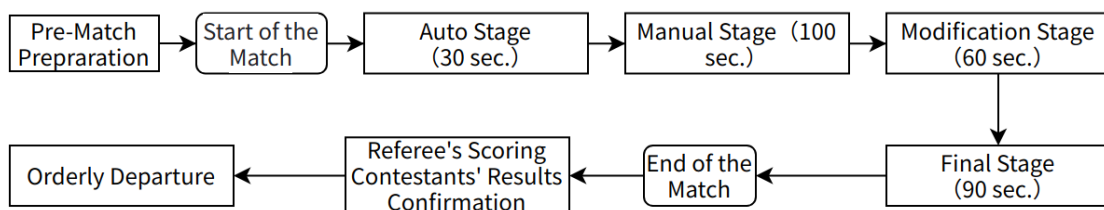

#### Pre-Match Preparation

Before a single match, contestants are required to check if their robots comply with the rule requirement and if the power management module has been installed correctly and works properly in the inspection area.

After entering the field, both alliances shall check whether the arena and props are placed in a standard way and whether the robots of both alliances are in a standard way. After cross-checking and approval, please follow the referee's instructions and



wait for the competition to start.

### Start of the Match

Contestants are not allowed to contact the robot after the referee's instruction to start the competition.

### Automatic Stage

The automatic stage lasts for 30 seconds.

To ensure competition fairness, robots in the starting area are required to power off. After the countdown of the automatic stage, the operator shall turn on the robot and the robot can run the preset automatic program.

### Manual Stage

The manual stage lasts for 100 seconds.

After the automatic stage ends, there is a preparation period before the manual stage begins. After the 5-second countdown by the referee, the 100-second manual stage begins. In the manual stage, the operator can control the robot with a Bluetooth controller.

Before the end of the manual stage, the referee will give a 5-second countdown reminder. After the countdown, the competition will move on to the modification stage.

### Modification Stage

The modification stage lasts for 60 seconds.

The modification stage begins after the end of the manual stage. Contestants are allowed to remove their robots (the vertical projections of the robots must be partially or completely in the starting area.) out of the arena and modify them. There are specifications for the length and width of the modified robot, and the height is not limited. **(Please refer to 6.3 Modification Rules for the specifications.)**

During the final 30 seconds of the enhancement modification stage, the competition system will issue a notification. As the modification stage approaches its end, there





will be a 10-second countdown. Before the countdown concludes, contestants must return their robots to the starting area (partially or completely). If, after the countdown ends, a participating team has not returned their robot to the starting area (partially or completely), the team's robot will be disabled during the modification stage. Once the robot is partially or completely placed in the starting area, if there are any acquired benefit resources, the team must request approval from the referee and partially or completely place the selected resources into their starting area.

### Final Stage

The final stage lasts for 90 seconds.

Before the final stage begins, the referee will determine whether or not both sides have acquired the benefit(s) based on the status of the reverse flag on the arena. If one side acquires the benefit(s), the alliance captain shall immediately make the relevant entitlement selection and implement it.

After a five-second countdown, the final stage begins and the operator can control the robot with a Bluetooth controller. During this stage, the alliance that acquired the benefit is allowed to operate their robots in the opponent's camp. At the end of the final stage, the competition will have a five-second countdown by referees. After the end of the match, the operator is required to stop controlling the robot place the Bluetooth controller in the storage basket and stay out of the arena.

### Referee's Scoring and Contestant's Results Confirmation

The referee will count the scores after the competition. If there is no objection to the competition, the captains of both alliances must confirm the match's result. If there is any doubt about the result, the captain of the alliance may appeal to the referee without signing the score sheet and write down the appeal in the remark column.

After the confirmation of the results, contestants shall actively assist the referee to restore the props and leave the competition area with their robots and Bluetooth controller in an orderly manner.



## 5. Technical Specifications

### 5.1 Specification for Robot Construction

The specification for robot construction provides a fair and safe competition standard for all teams and the committee encourages teams to make innovative designs of their robots on the prerequisites of meeting these specifications. The committee encourages teams to conduct hardware construction and software programming on the premise of observing the specifications. During the competition, it is a must for robots to abide by the specifications. Any robot that violates the specifications will be required to be modified. Those who commit serious offense will be punished for canceling the results or disqualification.

#### Robot Mechanical Specification

**T01.** The size specification of the robot is: before the modification stage: 500mm (length)\*500mm (width)\*700mm (height); After modification: 500mm (length) x 500mm (width), and with unlimited height. The length and width of robot are defined before the competition, without redefinition after the competition. When measuring the robot size, the flexible material on it should not be affected by external forces. (The flexible material includes but not limited to rolled strip, tape, foam block, etc.).

	Requirements	Details
Maximum Initial Size	500 mm (Length) 500 mm (Width) 700 mm (Height)	<p>1.The height should not exceed 700 mm and the vertical projection of the robot shall not exceed the square area of 500 x 500 mm.</p> <p>2.Before the modification stage, the robot's size must comply with the requirement of maximum initial size.</p> <p>3.The team should show the maximum size of the robot during the inspection.</p>



Maximum Modified Size	500 mm (Length) 500 mm (Width) Unlimited (Height)	1. There is no limitation on height and the vertical projection of the robot on the arena shall not exceed the rectangular area of 500 x 500 mm.  2. After the modification stage, the robot's size must comply with the requirement of the maximum modified size.  3. The team should show the maximum size of the robot during the inspection.
-----------------------	---	--

**T02.** The maximum net weight of the robot (during any time of the competition) shall not exceed 10 kg, including the weight of battery, all parts of the robot and excluding team flag.

**T03.** The robot must have a symbol with the team number or team name, with a single character higher than 3.5cm and a light background color so that the team can be clearly identified during the competition; if the symbol does not meet the requirements, the robot won't able to pass the inspection.

**T04.** Driving system: The main-board and moving robot chassis, including wheels, tracks or other mechanism structure that bring the robot into direct contact with the ground and move it over a flat field surface. For stationary robots or robots without a moving mechanism, the structure in direct contact with the ground is considered the driving system.

**T05.** Each team is only allowed to participate in competition with one robot. Teams may modify other structures of their robots during the Modification stage but cannot modify the driving system. If a team modifies the driving system, the team is considered to be using another robot and will be penalize by disqualification.

**T06.** If the replacement of some component because of its broken (e.g., wheel damage, motor failure, main-board failure, etc.), is not considered as the replacement of the driving system.

**T07.** The parts can be lubricated with lubricant, but contestants should protect the



arena from lubricant leaking.

**T08.** The following robot's parts that may cause danger are forbidden:

- (1) Sharp angle;
- (2) Oil pressure parts or hydraulic parts;
- (3) Switches or contacts containing mercury;
- (4) Parts that will conduct electrical current from robots to the arena;
- (5) Parts that tend to develop connections with other robots, such as hook-shaped parts and other parts;
- (6) Other dangerous parts as determined by the referees.

**T09.** The following hazardous materials are forbidden:

- (1) Flammable and explosive gases;
- (2) Materials containing liquids or gelatinous substances (except for glues and lubricants used in prescribed and small quantities);
- (3) Materials that may cause arena contamination, such as sand, ink, etc.;
- (4) Materials made from animal tissue;
- (5) Materials that may cause danger as determined by referees.

**T10.** Equipment with high performance that infringes the competition fairness is prohibited, it must be operated with the following performance indicators:

Equipment	Component	Specification	Note
Motor& Servo	DC Motor	<ul style="list-style-type: none"> <li>● 25 DC Motor</li> </ul> Rated Voltage: 6V Rated Rotation Speed : 50&200RPM	The total amount of Motor $\leq 13$ Total amount of servo $\leq 6$
		<ul style="list-style-type: none"> <li>● 37 DC Motor</li> </ul> Rated Voltage: 12V	The total amount of brush-less motor $\leq 2$



		Rated Rotation Speed : 50&200RPM	It is forbidden to change the mechanical structure and electrical layout of any motor or servo. Allows external welding without changing the performance of the motor.
Brush-less Motor	2823/2824 Brush-less Motor	Rated Voltage: 10000 mA MAX Rated Rotation Speed: 7300 rpm	
Encoder Motor	180 Smart Encoder Motor	Rated Voltage: 12V No-load Speed: 580±10%RPM Reduction Ratio: 39:43	
Smart Servo	MS-12A Smart Servo	Working Voltage: DC6V~12.6V Torque: 12kgf.cm	

**Robot Electronic Specification**

**T11.** Except for the laser sighting device, each robot can only be equipped with one battery, and the battery must be fixed inside the robot. The battery is prohibited from colliding with and separating from the robot.

**T12.** If the team use a laser sighting device on their robot, the power of the laser sighting device should be less than or equal to 5mW (below Grade 3 a/R), and at most one laser sight for one robot.

**T13.** The battery cables shall be intact without cracks, breakages and metal wires. There must be an electrical isolation between power supply lines and robot structures.

**T14.** Electronic equipment with high performance that infringes competition fairness is prohibited, it must be operated with the following performance indicators:

System	Module	Specification	Note
--------	--------	---------------	------



Power System	Li-Po Battery	<ul style="list-style-type: none"> <li>● 3S Li-Po Battery</li> </ul> <p>Output Voltage: 11.1V</p> <p>Discharge Rate: 25-30c</p> <p>Battery capacity: 4200mAh</p>	
Main-board System	Main-board	<ul style="list-style-type: none"> <li>● Processor: High-Performance M7 Processor</li> <li>● ATSAM32F030CCT6 Co-processor</li> </ul> <p>Working Voltage: 6V ~ 13V (The minimum input voltage of the motor is required to meet the requirement of the motor's working voltage)</p> <p>Communication Ports and Protocols: Serial Port /mBuild Protocol</p>	<p>Allowed to use Raspberry Pi 3 Model B+ at the same time</p>
Sensor System	Vision Sensor	<p>Viewing Angle: 65.0 degrees</p> <p>Effective Focal Length: 4.65±5%mm</p> <p>Identification Speed: 60 frames/seconds</p> <p>Identification Distance: 0.25-1.2m is the best range</p> <p>Method of Power Supply: 3.7V Lithium Battery or 5V mBuild Power Module</p> <p>Power Consumption Range: 0.9-</p>	<p>Type and quantity are not limited.</p> <p>It is forbidden for robots to use any sensors that will interfere with the perception ability of other robots</p>



		1.3W	
Wireless Control System	Bluetooth Controller	Bluetooth Version: Support 4.0+ Distance of Remission: 20m Working Current: $\leq 25\text{mA}$ Transmit Power: 4dBm Transmit Data: Data packets within 100ms can be acquired by Bluetooth devices (low latency) Battery: Two No.5 AA Dry Batteries Supported Platform: macOS / Windows	<ul style="list-style-type: none"> <li>● During the competition, one Bluetooth controller is available for one team;</li> <li>● The Bluetooth module shall connect with the Nova Pi mainboard</li> </ul>
	Bluetooth Module	Bluetooth Version: BT4.0 Band Range: 2402~2480MHz Antenna Gain: 1.5dBi Energy Consumption Grade: $\leq 4\text{dBm}$ Working Current: 15mA	It is forbidden to use any form of wireless control device to communicate with robots other than the official Bluetooth controller, including but not limited to any artificially triggered sensors

**T15.** Except for the buzzer embedded in the motor and main board, robots are not allowed to be equipped with any other electrical sound equipment. Except for indicator lights built into main controllers and sensors that comply with technical specifications, light sources used in conjunction with sensors, and laser targeting devices that comply with technical specifications, robots may use RGB LED lights up to 5V (inclusive) for decoration or status display, provided they do not interfere with the operations of other teams.



**T16.** Teams are allowed to self-construct or procure mechanical parts. It is suggested to use complete commercial product components with low integration, such as hinges, sprockets, roller chains and pulleys, etc. It is not allowed to use highly integrated complete commercial products, including but not limited to multi-DOF manipulators or mechanical hand.

## 5.2 Specification for Team Flag

**T17.** The specifications for the team flag are as below:

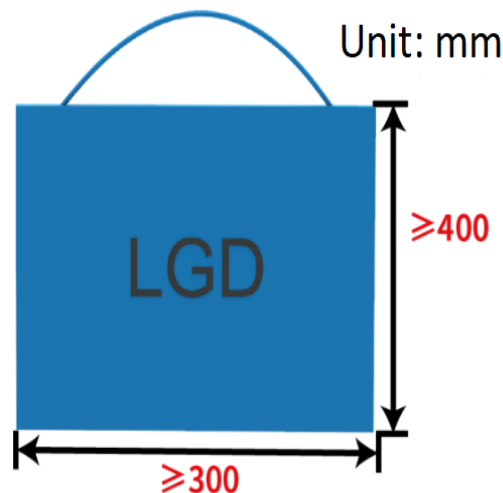

**Fig 5.2-1. The Size of Flag**

- The structure and shape of the flag should be referred to as the Fig5.2-1. It must be a regular-shaped flag; Shaped flags cannot be produced and used.
- The team flag shall consist of a flag surface and suspension components; a flagpole can be voluntarily added to the suspension components.
- The flag surface material shall be fabric, paper, or other flexible materials, and it must be a rectangular whole flag, with a size no less than 400 mm (length) x 300mm (width). It cannot be cut or shaped irregularly. The content of the flag must include the "team name," and the team name must be the official name of the participating team. No other team names may be marked or used on the flag.
- The flagpole portion of the suspension components may use rigid materials. If a flagpole is used, it may be made of rigid materials, but the length of the flagpole



must be equal to the length of the side it is hanging from, and the cross-sectional dimensions of the flagpole must be smaller than 10mm x 10mm.

- Irregular flagpoles or additional unusual weights of the suspension components are not allowed, otherwise, the self-made prop will be deemed non-compliant and considered an invalid scoring prop. The overall dimensions must not exceed 400mm (length) x 10mm (width) x 10mm (height).
- The committee encourages teams to draw personalized patterns or words on the flag, which calls for positive content reflecting the competition theme and spirit, without showing words or pictures related to the MakeX Robotics Competition Committee.

## 6. Competition Rules

### 6.1 Penalty

The penalty actions are categorized into four sections: "Safety Rules," "Participant Behavior Rules," "Operation Rules," and "Special Suspension."

During the Qualification Stage, penalties and penalty escalations are applied on a per-team basis. In other words, during this stage, if any team within an alliance receives a warning or point deduction, only that specific team will be subject to the corresponding penalty constraints. The other team within the same alliance will still have its own separate penalties and escalation opportunities, and the competition will proceed as normal.

During the Elimination Stage, penalties and penalty escalations are applied on an alliance-wide basis. This means that if any team within an alliance receives a warning or point deduction during this stage, both teams in the alliance will be subject to the corresponding penalty constraints. The exception is for suspension directives, which are handled on a per-team basis and penalized or constrained according to the specific circumstances.



### Warning

**E01.** The referee issues a warning to the team regarding their violation and requires the team to immediately cease the offending behavior. If the violation significantly impacts the fairness of the competition, the referee may pause the match as necessary and restore it to its pre-match state.

### Violation

**E02.** After the referee has reminded the team of the violation and asked for rectification if the same behavior is violated for a second time, the offending party will be deducted 20 points, and for the third or more (including the third time) of the same violation or related behaviors that are disrespectful to the referee, the penalty will be directly awarded to the team with 120 points.

### Suspension

**E03.** The referee issues a suspension to ask the robot to stop its action. The Referee is entitled to suspend robots according to the actual situation in the arena. The contestants shall ask the referee to suspend the robot while encountering robot malfunction or uncontrollably.

When special suspension is involved: the following two situations apply.

1. Malicious complaint: In a single match, it is prohibited for contestants to make malicious complaints against the opposing team.

After entering the competing area, if the complaining team confirms the need to raise a complaint with the referee, and the referee verifies and determines that the complained-about team has not committed any actual rule violations, the complaining team will be deemed to have made a malicious complaint. The robot of the offending team will be suspended.

2. During the Match, it is prohibited to directly contact any robot that is travelling or in motion on the field or any scoring props carried by the robot in motion. The referee has the right to determine whether this behavior affects the personal safety of the participating team members, and to



sentence the offending team to immediately suspend the robot, and at the same time, the referee may decide whether or not to remove the suspended robot from the field based on the actual situation.

### Disqualify for the Single Match

**E04.** The referee will disqualify the participating team from this match for serious violations, and the team's robot will be immediately suspended from further participation in this match, and the results of this match will be nullified, but will not affect other matches. If this penalty is triggered by a team in the qualification stage, it will not affect the results of the alliance's teammates. If this happens in the elimination round, the alliance will receive the penalty.

### Disqualify for the Entire Competition

**E05.** The robot will be suspended immediately and the team cannot participate in the competition and the following competition, all results will be disqualified. The team will lose the opportunity to continue to participate in the competition and the right to award.

## 6.2 Safety Rules

When the following safety rules are involved, the referee will issue a warning to the first offending party, and if the offending party still fails to rectify the situation, the robot will be suspended, and if the violation behavior has caused damage to the field or the opposing robot, a direct penalty of 120 points will be awarded and the robot will be suspended immediately.

### Dangerous Structure

**R01.** The measure of safety protection shall be taken if the robot's structure may cause damage to humans, such as sharp angles.

### Destructing or Contaminating Arena

**R02.** During the competition, robots are not allowed to maliciously "climb" or "collide" the arena boundary and the central partition.



**R03.** If arena contamination is caused by the robot, the robot will be regarded as in an unsafe state. Robots are not allowed to use double-sided tape or glue to fix arena elements during the competition.

### Destructing Other Robots

**R04.** During the competition, robots must not intentionally collide, overturn, entangle, or damage other robots in the arena. Reasonable confrontation is not penalized under this rule, and the determination of whether an action is intentional is made by the on-site referee.

### Robots Out of Boundary

**R05.** During the competition, any parts of the robot are not allowed to go beyond the arena boundary. The robot that goes beyond the boundary must return to its own area within three seconds and the referee will give a countdown reminder.

### Using Banned Materials

**R06.** The following hazardous materials or dangerous structures embedded in robots are forbidden, such as:

- (1) Flammable gases, fire or smoke generating equipment, hydraulic oil or hydraulic parts, switches or contacts containing liquid mercury (mercury);
- (2) Hazardous Substances (e.g., Lead);
- (3) Materials that may cause arena contamination, such as sand and other objects that may be scattered during competition;
- (4) Materials that develop connections with other robots;
- (5) Materials with sharp edges that may cause injury.
- (6) Materials made from animal tissue (for health and legal consideration).
- (7) Materials containing liquids or gelatinous substances (except for glues and lubricants).
- (8) Parts that can conduct electrical current from robots to any other parts in the arena.



## Other Unsafe Factors

**R07.** In addition to R06, referees are entitled to decide whether the robot is safe or not.

## 6.3 Participant Behavior Rules

When the following safety rules are involved, the referee will issue a warning to the first offending party, and if the offending party still fails to rectify the situation, the offending party will be disqualified for the single match or the entire competition. For the third time or more (including the third time) of the same offending behavior or related behavior of disrespect to the referee, a direct penalty of 120 points will be awarded and the match will continue, malicious complaints are not included.

### Participant Requirements

**R08.** One operator and one observer for each team. Each alliance includes two operators and two observers, and one of them is selected to be the captain of the alliance.

**R09.** It is not allowed for a third person as a substitution for on-arena players during the match. Operators are responsible for controlling the robot in each match. The operator and the observer can freely switch their roles during the match.

**R10.** Contestants shall tie up their long hair during competition preparation, robot debugging and on-field matches. Toe-bearing shoes are forbidden.

**R11.** Contestants shall wear goggles during the competition.

### Can't Arrival the Arena on Time

**R12.** Teams shall arrive on time. Teams that do not show up in the competing area over 5 minutes, will be treated as giving up this match voluntarily. If the whole competition schedule is delayed, please refer to the specific notice.

### Contestants' Standing Position

**R13.** Contestants shall stand in a certain range as shown in the following figure (the size of the operating area is subject to actual conditions):

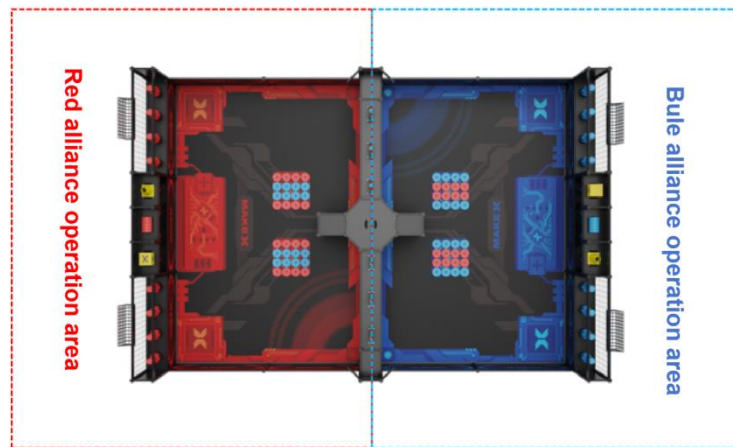

Fig. Standing Position of Operating Area

### Rules of Elimination Round

**R14.** During the BO3 match in the elimination round, after the end of each match, each alliance has 5 minutes to debug their robot and cannot do overtime.

### Malicious Complaints

**R15.** In a single match, it is prohibited for contestants to make malicious complaints against the opposing team.

- Malicious complaint: After entering the competing area, if the complaining team confirms the need to raise a complaint with the referee, and the referee verifies and determines that the complained-about team has not committed any actual rule violations, the complaining team will be deemed to have made a malicious complaint.
- The robot of the offending team will be suspended.

### Impolite Behavior

**R16.** During the match, the contestants shall promote positive competition spirit, respect the opponents and the referees, and shall not show impolite behavior (including malicious complaints, taunting, insults, fighting, etc.) to the referees or opponents.





## 6.4 Operation Rules

When the following operation rules are involved, the referee will issue a warning to the first offending party and ask the team to rectify it. For the second time offence behavior, the team will receive a 20 points deduction. For the third time or more (including the third time) of the same offending behavior or related behavior of disrespect to the referee, a penalty of 120 points will be awarded and the match will continue.

### Starting the match prematurely

**R17.** Robots must not be activated before the referee announces the start of the match.

### Delayed End of the Competition

**R18.** After the end of the automatic stage, manual stage and final stage, the operator shall stop controlling the robot or stop the robot's operation program (except for the motion caused by inertia).

### Using a Banned Electronic Device

**R19.** During the competition, it is not allowed for contestants to use electronic communication devices (mobile phone, transceiver, computer, wireless network devices, etc.) to get in contact with the offsite people.

### Using Bluetooth Controller in Automatic Stage

**R20.** Bluetooth controller shall be connected with the robot before the match. During the automatic stage, the blue-tooth controller shall be placed outside the arena; contestants are only allowed to pick up their blue-tooth controller after the automatic stage; after the manual stage, contestants must stop controlling their robot immediately.

### Operating Suspended Robot

**R21.** The operator is not allowed to control the robot after the robot is suspended.

### Robot's Left-Behind Components

**R22.** During the competition, the following situation is forbidden, such as detachment



of the robot and its components and left-behind mechanical devices (detachment refers to the detachment of robot ontology and its components). This rule is an exception to the shedding caused by the collision of the opponent's robot or direct contact with other robots.

### Robot In-conformity during the competition

**R23.** The size of the robot shall be in the state that is approved by both teams and the referees before the competition. Robots must comply with the size, weight and other parameters specifications throughout the match. Except for those situations that are caused by non-subjective factors, including being hit by opponents' arena element or other external forces, which leads to robots deforming or oversized.

### Toss in Violation

**R24.** Robots are not allowed to toss any arena elements except for the discs from their own camp to the opponent's camp (e.g., throwing pins, cones, robot parts, cubes, etc. will violate this rule).

### Violation of contact with the reversing flags

**R25.** During the competition, no part of the robot may directly contact and reverse a reversal flag (contact that does not result in flag reversal is excluded). If such an incident occurs, the referee will immediately pause the match and restore the flag to its original position.

### Code of Conduct for the Final Stage

At the start of the final stage, robots that have been granted access to the opponent's camp are subject to the following restrictions:

**R26.** Before the final stage, the vertical projection of the robot's chassis shall not partially or completely enter the opponent's area in any form.

- The robot that enters the opponent's area must return to its own area within three seconds, and the referee will give a countdown reminder. If the robot fails to return to its own area within three seconds, the team will receive a



violation with a 20-point deduction.

- If a robot partially or fully enters the opponent's camp during the automatic stage, it must return to its own camp within 3 seconds after the start of the manual stage.

**R27.** When the final stage begins, robot bodies and appendages (including launched/disengaged components) that are allowed into the opponent's area may not come into contact with the following targets, either directly or indirectly, in any way:

- a) Cube and cones in the opponent's central resource island area
- b) The team flag that is hanging on the flagpole.
- c) Pin that is in contact with the upper and lower recycling areas, with the inner edge of the flat aluminum of the recycling area as the boundary of the decision.

The contact caused by an active collision with the opposing team's robot will not be counted as an infraction and will be subject to the referee's on-site decision.

**R28.** When the final stage begins, the vertical projection of the robot's chassis that is not allowed to enter the opponent's area shall not partially or completely enter the opponent's area in any form. Once the robot gets into the opponent's area, it must return to its own camp within 3 seconds, otherwise the offending side will receive a violation and 20 points deducted.

**R29.** When the final stage begins, robots are not allowed to prevent robots that have the benefit to enter their camp from entering their camps by restricting the movement of the centre fence, or by blocking them head-on, etc.

### Restricting the Movement of Opponent's Robot

**R30.** Robots are not allowed to prevent the robot of the opponents' alliance from moving in all directions or touching arena elements. As part of the robot's ontology enters the opponent's camp, which leads to the other side's alliance robot being stopped or restricted, the competition will be suspended based on the actual situation, and robots of both alliances must be detached as soon as possible.



### Contact in Violation

**R31.** Except for the Modification Stage, the contestants shall not directly contact the arena elements such as the scoring props, the arena's frame the robots etc. during the match, including but not limited to the cases where the operator leans on the fence and the contestants push the robot. In case the direct contacts occur outside the arena due to the normal movement of discs or other props, they are not bound by this rule. Throughout the competition, robots may only change the state of flags by launching discs to strike them; they are not allowed to change the state of flags by directly or indirectly contacting them.

### Physical Interference

**R32.** To ensure an unblocked attacking router for the opponent, team members should keep their body projection out of the arena during the competition. This rule is the exception to the action of moving robots in and out of the arena during the modification stage.

### Mentoring in Violation

**R33.** No person (including but not limited to the parents or mentors of the team) other than the team members shall enter the competition area by any means, and no instruction shall be given in or outside the competition area in any form.

### Off-Arena Contact

**R34.** During the competition, contestants are not allowed to have any direct contact with off-arena persons and audiences, including but not limited to the delivery of the parts and Bluetooth controller.

## 6.5 Modification Rules

When the following modification rules are involved, the referee will issue a warning to the first offending party and ask the team to rectify it. For the second time offence behavior, the team will receive a 20 points deduction. For the third time or more (including the third time) of the same offending behavior or related behavior of



disrespect to the referee, a penalty of 120 points will be awarded and the match will continue.

#### **The Robot Not in the Starting Area Before the Modification Stage**

**R35.** At the end of the Manual Stage, the robot needs to be taken out from the Starting Area (partially or completed in the starting area) for modifications. In case the robot is not inside the Starting Area (Partially or Completely In), it will not be allowed to conduct any operations during the Modification Stage.

#### **Modify Outside the Designated Area**

**R36.** The team can only modify the robot after the vertical projection of the robot is completely out of the arena. Modification cannot be conducted when the robot is lifted just above the Arena.

#### **Changing the State of Arena Elements**

**R38.** When taking the robot out of the arena, contestants are not allowed to contact those scoring props that have no contact with the robot or change the state of scoring props.

**R39.** When taking the robot out of the arena, the robot cannot carry any scoring props except for the discs. The other scoring props shall be placed in the arena nearby.

#### **The Robot Not Inside the Starting Area Before the End of the Modification Stage**

**R40.** The robot shall be placed in its own Starting Area before the end of the Modification Stage.

#### **The Benefit Resource Not Inside the Starting Area**

**R41.** The benefit resource that the alliance get shall be placed in its own Starting Area before the end of the Modification Stage.

#### **The modified robot failed to match the check-in status.**

**R42.** The robot after the Modification Stage should conform to the modification state at the time of inspection, including but not limited to the Maximum Modification Size. (The height of the Robot is not limited.)



## 7. Appeal and Arbitration

### 7.1 Results Confirmation

#### Results Confirmation

When a single match ends, captains of both teams need to confirm the results with the referees and then sign the scoring sheet. Both teams shall not have any objection to the results of this single match after their signatures. If there is an error regarding the points calculation for each item on the paper scoring sheet, it will be corrected and confirmed by the resulting approval staff when checking the results; other result-related issues will not be dealt with, and the signed results will be valid.

#### Dispute Settlement

If the team has any objections to the results and the referee's explanation, they can refuse to sign the score sheet. Instead, they need to write clearly about the situation in the remarks part of the result form. The committee will only deal with appeals related to the reasons stated in the remark column of the paper scoring sheet.

### 7.2 Appeal Procedure and Valid Appeal Period

#### Appeal Procedure

Appeals should be lodged within the “valid appeal period” by the prescribed procedure and follow the civil participation spirit. The captain of the team needs to fill in the Appeal Form and then cooperate with the Arbitration Commission to investigate the actual situation. Both sides will be required to arrive at the designated place if the Arbitration Commission requires. During the investigation, the captain of the appeal team must be present, and only captains or contestants of both teams can be present. The Arbitration Commission has the right to communicate with the team alone, avoiding the mentor, the parents of the contestants, their relatives, or friends. The appellant should express facts clearly and objectively, not over-emotionally.

#### Valid Appeal Period



Normally, the appeal should be lodged within 30 minutes after the end of the competition. Please check the Program Brochure for a specific effective appeal period before the competition. The appellant and the respondent must be present at the designated place on time.

### Appeal Response

Normally, the Arbitration Commission responds to the appeal after the end of the competition on the same day or before the start of the competition on the next day.

## 7.3 Invalid Appeal

### Overdue Appeal

Appeals that are not lodged within the "valid appeal period" will be considered invalid and inadmissible. If the appellant fails to be present on time or leaves without any reason during the investigation, the appeal will be considered invalid. If the respondent fails to be present on time, the Arbitration Commission will directly determine the arbitration result and render it as a final result.

### Appellants out of Stipulation

The appellants must be the participating contestant and the appeal of another person is inadmissible. The Arbitration Committee will caution the offending team if parents, mentors, or other persons out of the stipulation participate in the arbitration process without the permission of the Arbitration Committee.

- The team or alliance will be disqualified entire competition for multiple invalid warnings.

### Vague Appeal's Requests

If the Arbitration Commission is unable to understand the appeal or conduct the normal investigation due to the emotional factor of the appealing party, the offending party will receive a verbal warning.

- The team or alliance will be disqualified entire competition for multiple invalid warnings.



## Uncivil Appeal

Neither side shall make uncivil behavior nor offensive actions and remarks.

- The team or alliance will be disqualified entire competition for multiple invalid warnings.

## 7.4 Arbitration Procedure

### Arbitration Procedure

The Arbitration Commission consists of the chief referee, the arbitration consultant, and the competition technical director. The Arbitration Commission is responsible for accepting the appeals and conducting arbitration investigations, to ensure the smooth progress of the competition and the fairness and justice of the competition results. The playback videos and photographs of any competition may be inaccurate due to the shooting angle, which is only used as reference but not arbitration evidence.

### Arbitration Results

The arbitration results can be divided into “maintaining the original result of the match” or “re-match”, and the two teams shall not appeal again. If the arbitration result is a "re-match", the two teams shall have a re-match according to the time and arena stipulated in the Appeal Form. If either team fails to reach the arena within 5 minutes after the beginning of the match, the team shall be deemed to quit the match.

### Additional Remarks

The Arbitration Commission determines the final arbitration result, and neither side shall dispute the result of the appeal anymore.

## 8. Statement

MakeX Robotics Competition Committee reserves the final interpretation of *the 2024-2025 MakeX Challenge Ultimate Winner Rules Guide*.

## 8.1 Rules Explanation

To ensure fair competition and high-quality competition experience, the MakeX Robotics Competition Committee has the right to update and complement this Rules Guide regularly, and issue and implement the latest version before the competition.

During the competition, all matters not stated in the Rules Guide shall be decided by the referee team.

This Rules Guide is the basis for refereeing, and the referee team has the right to adjudication during the competition.

## 8.2 Disclaimer

All contestants in the MakeX Robotics Competition shall fully understand that safety is the most important issue for the sustainable development of the MakeX Robotics Competition. To protect the rights and interests of all contestants and organizers, according to relevant laws and regulations, all contestants registered for the 2024 MakeX Robotics Competition, shall acknowledge and abide by the following safety provisions:

- (1) Contestants shall take adequate safety precautions when constructing the robots, and all parts used for constructing the robots shall be purchased from legal manufacturers.
- (2) Contestants shall ensure that the structural design of the robots takes into account the convenience of the inspection and actively cooperate with the host of the competition.
- (3) When modifying and using the parts with potential safety hazards for the robots, it must conform to the national laws, regulations, and quality & safety standards. Those operations shall be manufactured and operated by persons with relevant professional qualifications.
- (4) During the competition, the teams shall ensure that all the actions such as construction, testing, and preparation will not do harm to their team and other teams, referees, staff, audiences, equipment, and arenas.



- (5) In the process of construction and competition, if any action that may violate the national laws, regulations, or standards occur, all consequences will be borne by the contestants themselves.

The competition kits and parts sold and provided by the supporter, MakeX Robotics Competition Committee, shall be used according to the instructions. MakeX Robotics Competition Committee will not be responsible for any injury or loss of property caused by improper use.

The official language for MakeX is Chinese. English or other language translations are prepared to facilitate the team's preparation process. All documents translated into English are for reference only.

### **8.3 Copyright Declaration**

MakeX Robotics Competition Committee reserves the copyright of this Rules Guide. Without the written consent or authorization from the MakeX Robotics Competition Committee, any entity or individual may not reproduce, including but not limited to any network media, electronic media or written media.



## Appendix 1. Awards and Annual Points

In the 2024-2025 season, according to the scale of the competition and the number of teams, the competition will be classified into Points Race/Regional Competition, National Competition, International/Intercontinental Competition, and World Championship. In the MakeX Challenge Ultimate Winner competition, teams can obtain points based on the number of wins, ties and losses in the match. Each team can voluntarily sign up for all kinds of Points Race all year round to accumulate annual points. The accumulation of annual points is based on the Team Number.

In a single-point race, teams can obtain annual points based on the winning points in the qualification round and elimination rounds.

Competition Type	Rounds	Win	Tie	Loss
Points Race/Regional Competition	Qualification	5	2	1
	Elimination (Best of 3)	10	/	2
National Competition	Qualification	10	4	2
	Elimination (Best of 3)	20	/	4
International/Intercontinental Competition	Qualification	15	6	3
	Elimination (Best of 3)	30	/	6

Teams that have won the champion, runner-up, second runner-up and other awards can obtain additional annual points. For the details of the award list, please refer to **the MakeX Awards Guide**.

Category	Awards	Regional /Points Race	National	International/Intercontinental
Special Award	Champion	15	30	45
	Runner-up	10	20	30



	Second runner-up	5	10	15
	Innovative Design Award	-	5	10
	Engineering Notebook Award	-	5	10
Comprehensive Award	Outstanding Mentor Award	-	-	-
	Promotion Ambassador Award	-	5	10
	Technology Sharing Award	-	5	10
	MakeX Spirit Award	-	-	10

For example, team X20000 obtains the champion in one Points Race, and all the results show as below.

Qualification Round 1	Qualification Round 2	Qualification Round 3	Qualification Round 4	Annual Points from Qualification Round=13
Win (5)	Loss (1)	Tie (2)	Win (5)	
Top Eight Battle	Semi-final	Final		Annual Points from Elimination Round=30
Win (10)	Win (10)	Win (10)		

The total annual points that team X20000 obtains = 13+30+15 = 58.



## Appendix 2. Engineering Notebook Guideline

### \*Instruction:

1. The value of an engineering notebook: It helps the team establish files and record the whole learning process. Therefore, it is necessary to record engineering notebooks during the entire preparation for the competition.

2. Engineering notebook submission: Teams can use online documents or handwriting. No matter which way to use it, each team must submit a paper version onsite.

Paper engineering notebook: As the Challenge programs require the assessment process, one copy of the paper version shall be submitted by each team to the judges onsite. If there is no assessment process (Starter & Explorer), each team will need to submit one copy of the paper version to the staff at the inspection area. Teams that cannot submit the original engineering notebook should prepare their copies.

3. An engineering notebook will be required for the evaluation of all technical awards. Please refer to the Competition Guide for the evaluation criteria.

### **Basic Requirements for Cover**

The team's name, team number, and competition program must appear on the cover of the engineering notebook.

### **Basic Requirements for Contents**

#### **1. Clear content**

Creating content brings convenience for the judges to review and quickly find the corresponding section.

#### **2. Process records (Required)**

Every improvement of the robots should be recorded from prototype design, construction, to the debugging. Keep pictures of all manuscripts, design drawings, calculation processes, circuit diagrams, etc., and insert them into the engineering notebook in the form of pictures.

1) Schedule of robot building progress



- 2) Design inspiration/sketch
- 3) Technical principle (it can be disassembled into different parts)
- 4) Production step by step (with clear pictures)
- 5) Problems encountered and solutions

Examples of problems:

What technical failures did you encounter? Why did you fail? How did you solve the problems finally?

What efforts have you made for the robots? What improvements have been achieved?

Does your project progress schedule go as planned? What accidents or delays have occurred? How to fix it?

Have there been any disputes among the team members and how to settle them in the end?

### 3. **Projects summary**

- 1) The structure and function of the project (with pictures and text enclosed)
- 2) The technical innovations of the project
- 3) Competition strategies for scoring and defense

### 4. **Team introduction**

- 1) A brief biography of each team member and their role on the team
- 2) Culture displaying (logo, team flag, slogan, posters, T-shirt, etc.)
- 3) Excellent achievements sharing (Stories)

### 5. **Feelings and other things you want to share (optional)**

- 1) Achievement in the competition (Technical)
- 2) Growth in the competition (Spiritual)
- 3) Suggestions for competition



## Appendix 3 Robot Self-Check Form

# MakeX Challenge Ultimate Winner Robot Self-Check Form

Please follow the requirements of the self-checklist and check the box if your robot meets the requirements. And submit the signed self-checklist during the inspection day. Thanks for your cooperation.

Team Number: \_\_\_\_\_ Team Name: \_\_\_\_\_  
 Mentor Name: \_\_\_\_\_  
 Actual attended Team Member: \_\_\_\_\_

<b>1. Basic Information</b>	
<b>Power Management Module Bit Code:</b> _____ (A 4-bit code consists of numbers and an alphabet, eg: 004C)	
<b>Robot Size: Length</b> _____ <b>mm, Wide</b> _____ <b>mm, Height</b> _____ <b>mm.</b> (Robot size should not exceed: length 500mm, width 500mm, height 700mm. Please measure your robot and fill in the maximum extension size)	
<b>Robot Weight:</b> _____ <b>kg (Should not exceed 10kg)</b>	
<b>Self-made Flag: Length</b> _____ <b>mm, Wide</b> _____ <b>mm</b> (Flag surface is no less than 400mm(length)* 300mm(wide). The flag surface is made of flexible materials, and the flagpole is allowed to use hard materials)	
<b>2. Equipment</b>	
<b>Quantity of DC motor &amp; Encoder motor (37DC Motor&amp;180 Smart Encoder Motor) ≤ 13</b>	<input type="checkbox"/> Yes
<b>Servos (MS-12A) ≤ 6</b>	<input type="checkbox"/> Yes
<b>Brush-less Motor (2823/2824 Brush-less Motor) ≤ 2</b>	<input type="checkbox"/> Yes
<b>Quantity of Bluetooth controller: 1</b>	<input type="checkbox"/> Yes
<b>Wireless control: Bluetooth version: BT4.0</b>	<input type="checkbox"/> Yes
<b>Name and parameters of battery: (3S Li-Po Battery, Output Voltage: 11.1V</b>	
<b>Discharge Rate: 25-30c, Battery capacity: 4200mAh)</b>	<input type="checkbox"/> Yes
<b>Quantity of battery is one.</b>	<input type="checkbox"/> Yes





<b>3. Others</b>			
<b>SN</b>	<b>Items</b>	<b>Specific Requirements</b>	<b>Meet Requirement</b>
1	Dangerous Structure	The robot's structure that may harm people is required to ensure safety protection during robot handling and transporting.	<input type="checkbox"/> Meet Requirement
2	Competition Area Destruction	Competition area destruction is prohibited in the process of robot loading, unloading and transporting.	<input type="checkbox"/> Meet Requirement
3	High-power Equipment	High-power equipment is not available during the assembling and operation of the robot.	<input type="checkbox"/> Meet Requirement
4	Unsafe Energy Storage Equipment	Please keep safe while using energy storage devices (spring).	<input type="checkbox"/> Meet Requirement
5	Banned Material	Robots are not allowed to use the flammable gases, pyrotechnic equipment, hydraulic components, mercury-containing components, exposed hazardous materials, unsafe counterweights, designs that may cause entanglement and competition delays, sharp edges and angles, materials containing liquids or gelatinous substances, and any part that the electric current on the robot may be conducted to the competition area.	<input type="checkbox"/> Meet Requirement
6	Personal Safety	Contestants shall wear goggles; long hairs shall be tied up; contestants are prohibited from wearing toe-baring shoes to enter the competition area.	<input type="checkbox"/> Yes
7	Luminous/Acoustic Sensor	Excluding the built-in buzzer of the motor and main control unit, the robot is not allowed to use any electronic sound-producing devices. Aside from the indicator lights of the main control and sensors that comply with technical specifications, light sources used in conjunction with sensors, and laser aiming devices that meet technical specifications,	<input type="checkbox"/> Yes



		<p>the robot may use RGB LED lights with a voltage of 5V or below (including 5V) for decoration or status display, provided they do not interfere with the operation of other teams.</p> <p>If a laser aiming device modified from a teaching laser pointer requires separate power, only the built-in paired battery (such as AA batteries) may be used, and it must not supply energy to the robot's power system. For uncommon laser aiming devices, please provide the corresponding model and parameters for verification.</p>	
8	Self-Customized Parts and Accessories	<p>Self-customized parts can be used: plates, profiled materials, 3D printing pieces, metals, wood, plastics, rubber, magnets; Usage requirements for auxiliary materials: It is allowed to use the ropes, cables, wires, springs, rubber bands, leather hoses, surgical tubing, punched sheets, injection molded products; It can use commercial product components with low integration instead of higher integration.</p>	<input type="checkbox"/> Yes
9	Wrap the Sharp Structure	<p>The exposed sharp edges of the robots have to be wrapped with sponge strips.</p>	<input type="checkbox"/> Yes
10	Detachment/Shedding	<p>Detachment of the robot and its component is forbidden during the competition.</p>	<input type="checkbox"/> Yes
11	Interference	<p>It is prohibited to interfere with the electronics and sensors of other robots.</p>	<input type="checkbox"/> Yes
12	Team Number	<p>Team number's printing font should be Microsoft YaHei, black bold, 130 font sizes, and the background should be in light color.</p>	<input type="checkbox"/> Yes
13	Engineering Notebook Submission	<p>Submitting project notebook containing robot control source code before the competition.</p>	<input type="checkbox"/> Yes
14	Contaminating Competition	<p>The lubricant and other materials used by robots shall not contaminate the arena or other robots.</p>	<input type="checkbox"/> Yes



	Area		
--	------	--	--

Our team has checked our own robot according to the self-check form has filled in the actual data on this form and submitted it to the MakeX Robotics Committee. We promise that we will participate in the competition in the above state and will report any changes in time. During the competition, if the robot does not comply with the requirement or our team uses any in-compliance robot, the competition result will be disqualified and all responsibilities will be taken by the team without objection.

Team Leader/Mentor Signature:

Date:



# Appendix 4 MakeX Challenge Score Sheet

## MAKEX ROBOTICS COMPETITION

### 2024-2025 MakeX Challenge Ultimate Winner--Scoring Sheet

Competition Info: Qualification Round  / Elimination Round  (Arena) No. \_\_\_ (Session)

Team Registration		Match Points				Winner
Red Alliance		Red Alliance Score & Quantity		Blue Alliance Score & Quantity		Red Alliance
Team 1 (No.):		10pts/each		Discs	10pts/each	
Team 2 (No.):		20pts/each		Pins in the upper layer	20pts/each	
		30pts/each		Pins in the lower layer	30pts/each	
		30pts/each		Reversal Flag	30pts/each	
		30pts/each		Cube or Cone	30pts/each	
		200pts/300pts		Bonus for cube/cone(200pts) Bonus for MAKEX cube(100pts)	200pts/300pts	
Team 1 (No.):				Hanging Flag Own 50pts Opponent 80pts		
Team 2 (No.):				Penalty		
				Total Points		
Captain of Red Alliance		Captain of Blue Alliance		Remark		
<i>(Please confirm the scoring results and sign here.)</i>		<i>(Please confirm the scoring results and sign here.)</i>		<i>(If there's any disagreement about the results, please write down the situation clearly and sign here.)</i>		
Referee Signature		Referee Signature				
<i>(Please confirm the scoring results and sign here.)</i>		<i>(Please confirm the scoring results and sign here.)</i>				



## Appendix 5 Instructions for Li-Po Battery

To ensure the safety of the Li-Po battery, each team should designate a person to supervise the usage of the battery and to inform the teammates about the safety instructions for the Li-Po battery. The following issues should be noted while using Li-Po battery:

- Please use the Li-Po battery while ensuring that you carefully read and understand the safety instructions.
- Safely charging and discharging.
- It is required to use the specified charger for the Li-Po battery provided by the manufacturer, as well as read the instructions for the charger carefully. In case of emergencies to be dealt with, please ensure that someone is nearby during charging. Please do not overcharge or overcharge. It will be deemed overcharged if the voltage of a single battery cell is over 4.2v, and less than 3.0v is over-discharged. Overcharge may cause the explosion of the Li-Po battery, while over-discharge can easily damage the battery and shorten its service life.
- Please check the battery's voltage and electricity quantity carefully before charging or using it.
- Please charge the battery at 0-45 °C.
- Safe storage
- The battery cell cannot be overheated at any time. When the temperature of the battery cell is as high as 60°C, there will be potential safety hazards, even burning.
- In the process of charging, the battery is not required to be closed or placed directly on flammable materials (paper, plastic, etc.). If conditions permit, it is best to charge it in a fire-proof safe box.
- Please do not put batteries near liquids, open fires or heaters. Place batteries out of reach by kids.



- Please do not detach and restructure the batteries arbitrarily or change their wiring, do not assemble the batteries privately. The following behaviors are deemed as dangerous: detach and restructure the old battery cells, or restructure one of the detached battery cells with another restructured one (It can easily cause short-circuit combustion without the particular assembly instrument).
- If a occurs collision during the competition, please take out the battery. Please carefully check the state of the battery and connector. (Note: Batteries may be overheated with high temperatures.)
- Do not spill electrolytes on the eyes or skin. In case it spills inadvertently, please wash it with clean water immediately. In case it is serious, please seek medical care immediately.
- No short circuit is allowed (positive and negative poles are connected).
- Do not directly contact the leaked battery.
- For batteries that have not been used for a long time, please ensure a charge-discharge activation within 3 months to maintain stability.
- During the storage and transportation of Li-Po batteries, please place them in special fire-proof safety bags or safety boxes.



## Appendix 6 Power Management Module

### Introduction of Power Management Module

The power management module is used in coordination with the main board (NovaPi), which is a necessary electronic device to participate in the competitions of the 2024-2025 Season Ultimate Winner and Ultimate Warrior.

Module Size: 85mm(length) x 56mm(width) x 11.5mm(height);

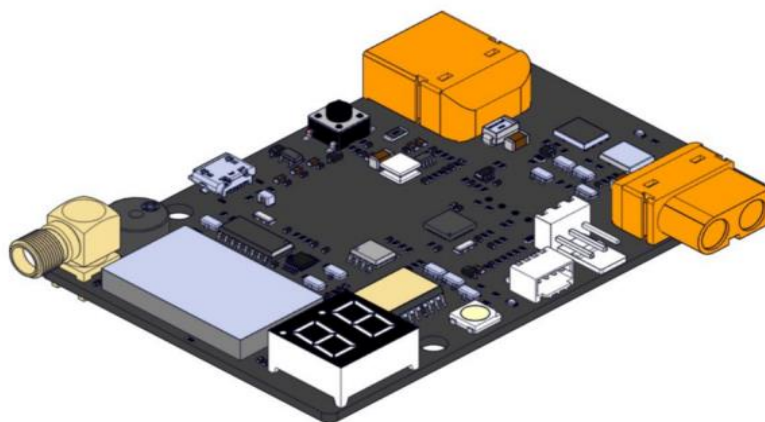
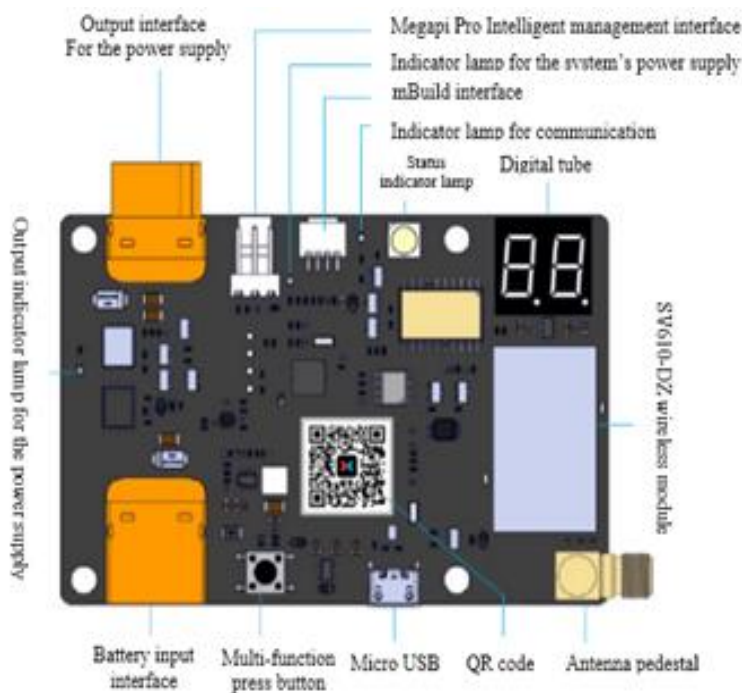



**Working Voltage:** 6V - 12V;

### **On-board LED Lamp**

LED Lamp includes an indicator lamp for power output, an indicator lamp for system power and an indicator lamp for communication

- **Indicator Lamp for Power Output:** The red indicator lamp is always on when having power output, and goes off when the power is disconnected.
- **Indicator Lamp for System Power:** The red indicator lamp for system power is always on when the module is working.
- **Indicator Lamp for Communication:** The blue indicator for lamp communication flashes when the module updates its firmware.

### **Indicator Lamp for Status (RGB Lamp)**

Indicator lamp for status mainly includes four statuses: power off, red, green and blue.

- **Power Off:** The Bluetooth module is detected after the power management module is powered on. The RGB lamp is powered off when the Bluetooth module cannot be detected.
- **Red:** After a normal power-on, click the button and the RGB lamp flashes red once;
- **Green:** In the manual stage;
- **Blue:** In the automatic stage.

### **Digital Tube**

The two-digit digital tube is mainly used to display the current channel and an abnormal state of the wireless communication module.

- In the normal state, the channel number of the current wireless communication module is displayed by the two-digit digital tube. The channel number of the wireless communication module is 1~40, so that the number displayed by the digital tube is 1~40. If the current channel is 16 channels, the two-digit digital tube displays the number "16".
- The power management module will detect the wireless communication module when it is powered on. If the wireless communication module cannot be detected, the 2-digit digital tube will display the letter "Er", meaning error.





- When the battery is low powered, the two-digit digital tube displays the symbol "-" and the current channel number alternately.

### Buzzer

The buzzer will send the sounds of reminding and warning.

- The buzzer will shortly buzz when the module is normally powered on and be detected, together with the wireless communication module is online;
- When the power management module is reset, the buzzer will sound for 2 seconds;
- When the wireless communication module cannot be detected after power-on, the buzzer rings three times continuously.

### Operation of Power Management Module

#### Multi-function Button

Multifunctional button has four modes: reset, click, double-click and long-press.

- **Reset:** Firstly, press the multi-function button and meanwhile insert the Li-Po battery into the power management module. The power management module restores the default configuration parameters. The buzzer sounds for 2 seconds and the digital tube displays the number "20";
- **Click:** Click the multi-function button once, the power management module reports the Bluetooth module UID once, and the RGB lamp flashes red once.
- **Double Click:** Double click the multi-function button once, the power management module will delay 3 seconds and switch between the automatic program and manual program (It can be observed whether the state switch is successful through the RGB indicator, the RGB blue lamp is always on during automatic stage, the RGB green lamp is always on during manual stage, and the RGB lamp flashes during the delayed switching). Double click is only valid when the Bluetooth module is defaulted to "20" channel (It is only valid when the digital tube displays the number "20");
- **Long Press:** Long press the multi-function button (2-3 sec.) to switch the output state of the power supply. That is if the current power is disconnected,

the power will connect after long pressing and its indicator lamp becomes red.  
If the power connects, the power will disconnect after long pressing and its indicator lamp powers off.

### Starting Signal Identification Code of Automatic Program

In automatic stage, the competition system sends relevant instructions to the power management module of the robot, so as to shield the controller signal and start the automatic program of the robot. In order to start the automatic program on the mainboard normally, it is necessary to insert a fixed code into the program to identify the instructions to start the automatic program sent by the competition system.

(Please put the program in manual stage and automatic stage into the corresponding positions.)

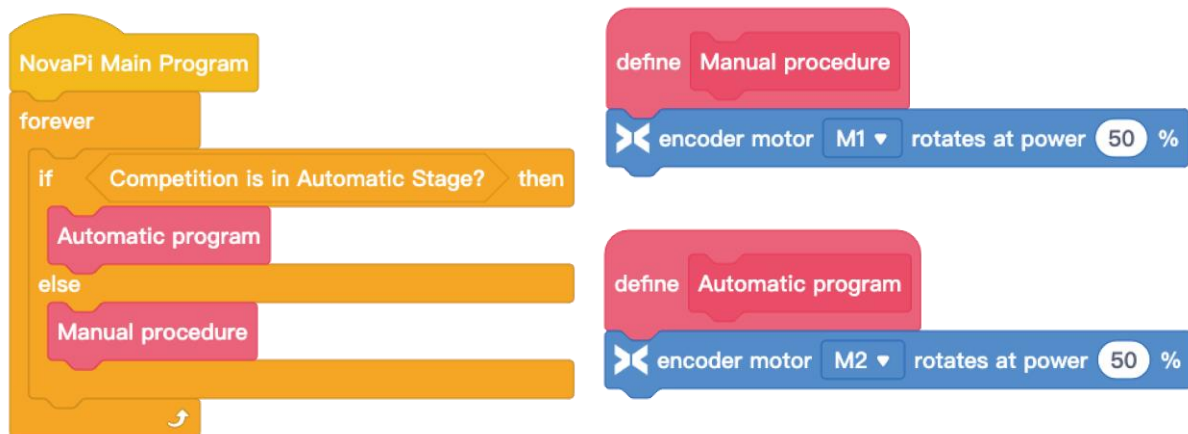

### Installation Manual

- The power management module is a necessary electronic component for the competition. Please make sure that it is securely fixed, and cables are tightly connected. For protection, it is suggested to use an acrylic box of power management module;
- The data cables leading to the mainboard must be connected firmly as follows:

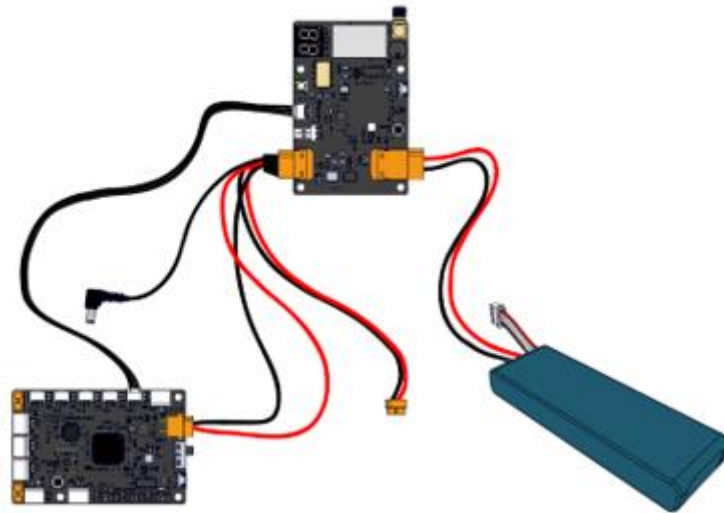

- Adjust the position of the antenna to prevent it from interfering with the movement of other motion devices, and try to avoid the antenna exposed to metal materials;
- The power management module must be fixed on the surface of the robot and be accessible to scan (power management module ID);
- The following operations are not allowed at any stage after the start of the competition, especially during the modification stage:
  - a. The replacement of Li-Po battery or re-unplugging and re-plugging of the Li-Po battery.
  - b. Press the reset button of the power management module (any operation of the power management module is prohibited).
- When the competition is finished, the robot needs to be re-powered by itself, and the power supply can be restored by unplugging and plugging the Li-Po battery;
- The power management module corresponds to the teams' information in the competition system one by one. Please do not replace that module without authorization. If it needs to be replaced, please contact the staff. Any problems caused by the unauthorized replacement of the power module shall be borne by the team.



## Appendix 7 Supplementary Explanation of Competition Procedure

### Engineering Notebook Submission

MakeX Robotics Competition Committee encourages teams to record engineering notes, and excellent notes will be an important basis for the team's award evaluation. The submission of paper engineering notebook and award setting based on pre-match notice and program brochure. Generally speaking, the submission of paper engineering notes is necessary in medium and large-scale events, which will serve as an important basis for the award evaluation. Please refer to **Appendix 2 Engineering Notebook Guideline**.

### Pits Area Decoration

Each team has its own space in the pits area, where teams can decorate their space to make their teams known to people, and participate in the award evaluation. Teams can rest and debug robots in the pits area, and please keep the area clean and tidy. The suggestions are as follows:

1. Display Content (provided by teams)
  - (1) Team Flag
  - (2) HD Images (3-4 copies)
  - (3) Team Introduction (no more than 200 words)
  - (4) Peripheral Display (if any)

2. Display Form

Team Poster/Roll Up Banner + Team Flag + Team Peripheral (if any) + Team Members/Teachers' Onsite Suggestion

### Practice Round

Teams who have finished their robot inspection can participate in practice round. The schedule will be announced at the entrance in form of notices, and teams are required to queue in line before entrance. Not all competitions have a practice



round, which can be informed based on actual situation.

### **Team Assessment**

MakeX encourages contestants to master theoretical knowledge of robots as well as develop their creativity and skills of making robots by participating in the competition. By the method of Q&A and onsite problem-solving, the assessment with 10 minutes will be conducted to examine students' knowledge of robots. In this procedure, all team members must participate together except their mentors. Each team should attend the assessment on time, with 1 copy of the engineering notebook and the robot. The assessment, with its aim to examine students' knowledge of robot, will be conducted in three aspects, including basic robotics theory, machinery and programming as well as innovation. The judges will ask questions or require an onsite operation demonstration. In a regular points race, teams can obtain different score (5, 3, 2, 0) based on their onsite performance grade (S, A, B, C). The assessment result will be announced on the MakeX official website after the qualification round. Teams obtaining zero point in the assessment procedure will not be able to enter the elimination round. The assessment score will be adjusted accordingly for different grade of point races.



## Appendix 8 Arena Assembly Instruction

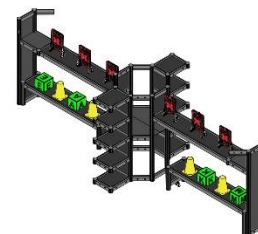
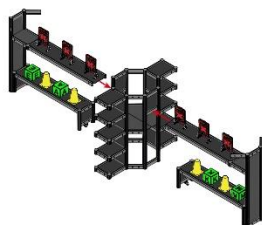
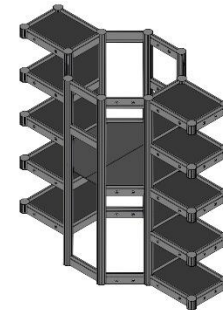
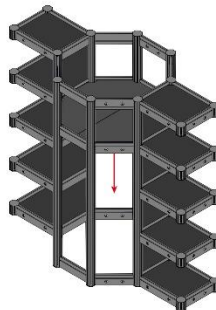
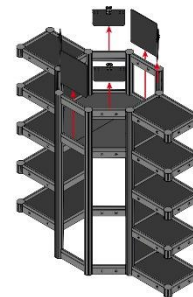
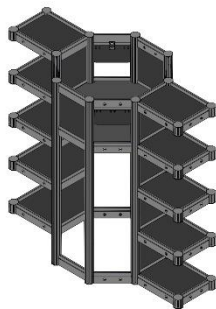
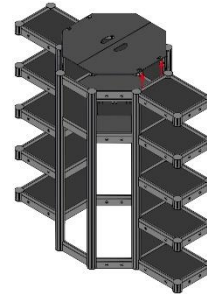
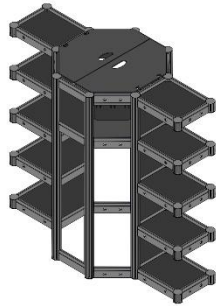

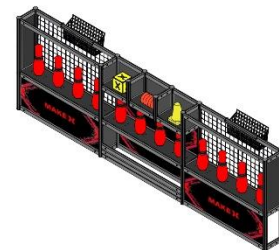
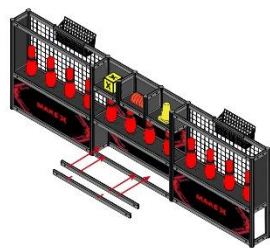
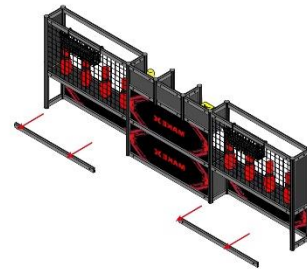
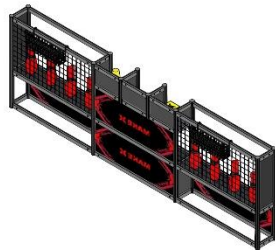
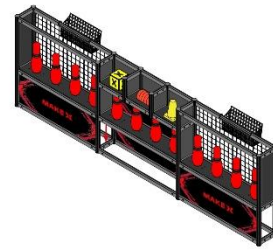
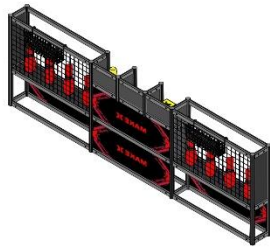
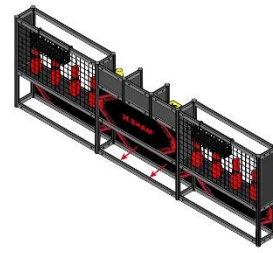
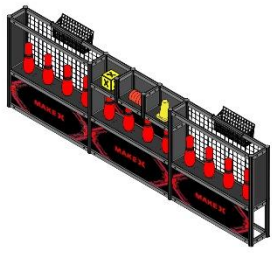



## Appendix 9 Competition Resources

Competition resources include but are not limited to official resources provided by the committee, such as Competition Guide, Equipment Instructions, Rules Videos, etc.

The contestants are obliged to keep abreast of the update of competition resources before the competition, and any problems caused by the contestants' failure to keep abreast of the updates shall be borne by the contestants themselves. All official competition resources will be updated in MakeX Website.

MakeX Robotics Competition Committee will revise and improve the Rules Guide with the progress of the competition and the new version will be announced in MakeX Website. The contestants and mentors can download the latest version in MakeX Website.

MakeX Website Download <https://www.makex.cc/en/information/download>.

MakeX Official Website: <https://www.makex.cc/en>.

Any Feedback & Question Please Sent to:

[makex\\_overseas@makeblock.com](mailto:makex_overseas@makeblock.com)



**MAKE** ><

Edited By Makex Robotics Competition Committee

RULES GUIDE

MAKEEX CHALLENGE

Official Website:  
[www.makex.cc/en](http://www.makex.cc/en)

Email:  
[makex\\_overseasa@makeblock.com](mailto:makex_overseasa@makeblock.com)

 Facebook : Makex